



**Trabon<sup>®</sup>  
Modu-Flo<sup>®</sup>  
Pumps  
Reservoirs  
Lube  
Packages  
Accessories**

- Modu-Flo concept provides a proven, cost-effective way to assemble customized oil or grease lubrication systems that meet specific requirements by using standard modular components.
- Modu-Flo increases opportunities to standardize lube system components and reduces lube maintenance and service costs.
- Modu-Flo saves you system design dollars and lead time.
- Modu-Flo components are dependable and backed by the industry's most comprehensive international distributor network—with application expertise, stocked parts and factory-trained service nearby, wherever you are located.

# Modu-Flo = true modularity

Wide choice of standard modular components helps you meet application requirements more exactly without the added cost of a custom system.

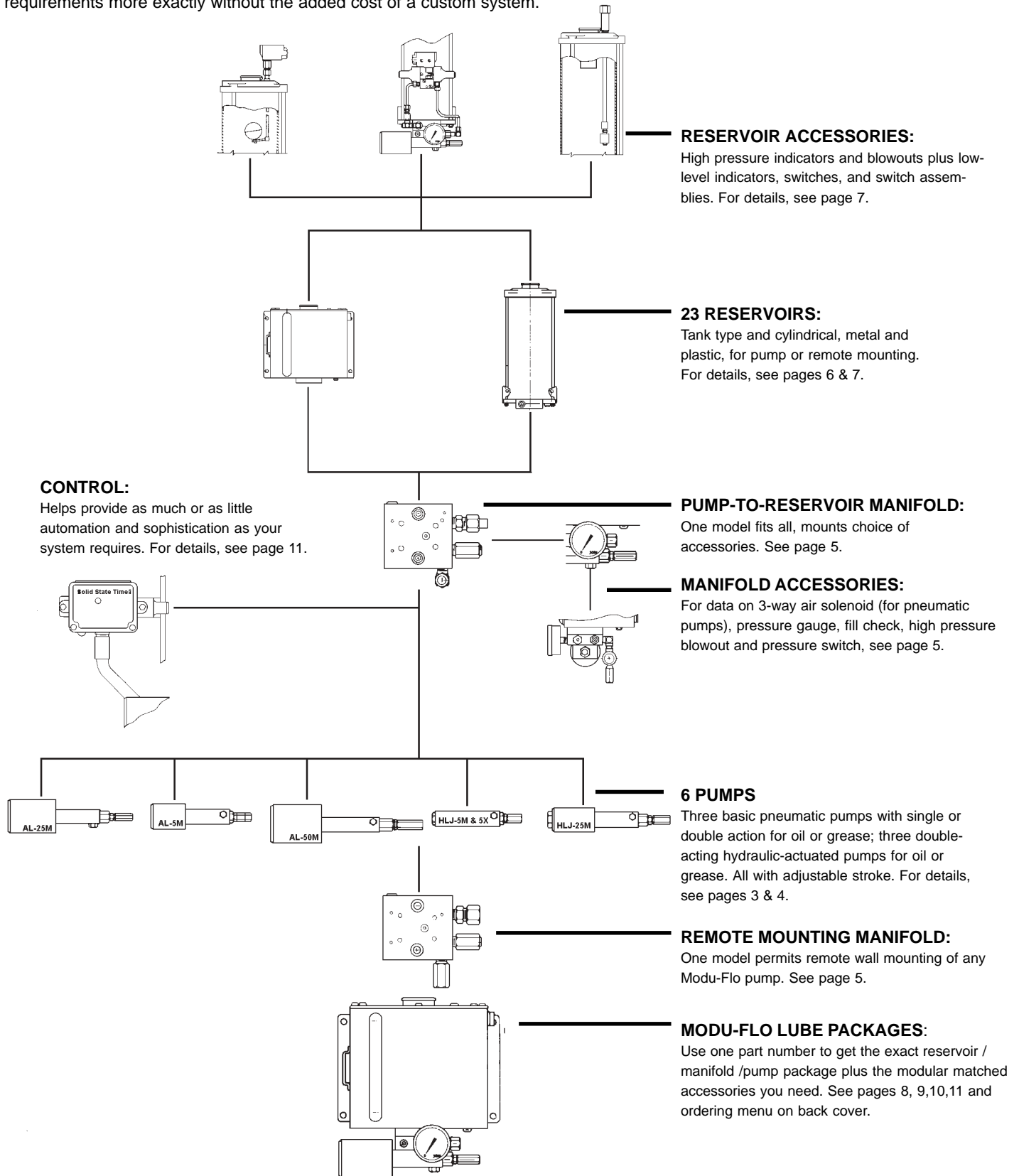

**RESERVOIR ACCESSORIES:**

High pressure indicators and blowouts plus low-level indicators, switches, and switch assemblies. For details, see page 7.

**23 RESERVOIRS:**

Tank type and cylindrical, metal and plastic, for pump or remote mounting. For details, see pages 6 & 7.

**CONTROL:**

Helps provide as much or as little automation and sophistication as your system requires. For details, see page 11.

**PUMP-TO-RESERVOIR MANIFOLD:**

One model fits all, mounts choice of accessories. See page 5.

**MANIFOLD ACCESSORIES:**

For data on 3-way air solenoid (for pneumatic pumps), pressure gauge, fill check, high pressure blowout and pressure switch, see page 5.

**6 PUMPS**

Three basic pneumatic pumps with single or double action for oil or grease; three double-acting hydraulic-actuated pumps for oil or grease. All with adjustable stroke. For details, see pages 3 & 4.

**REMOTE MOUNTING MANIFOLD:**

One model permits remote wall mounting of any Modu-Flo pump. See page 5.

**MODU-FLO LUBE PACKAGES:**

Use one part number to get the exact reservoir / manifold / pump package plus the modular matched accessories you need. See pages 8, 9,10,11 and ordering menu on back cover.

# Modu-Flo®

## PUMPS



Pneumatic AL Pump



Hydraulic HLJ Pump

There are six Modu-Flo pneumatic and hydraulic actuated pump models for series progressive oil or grease systems. Three pneumatic models carry the AL prefix. They are actuated by air pressure from 40 to 150 psi (2.76 to 10.3 bar), and have a lube-to-air pressure ratio of 30:1. They can be set up to be single- or double-acting, depending on the system requirements.

Two hydraulic-actuated models carry an HLJ prefix. They are double-acting, operate on hydraulic pressure from 200 to 2,000 psi (13.8 to 137.9 bar), and have a lube-to-hydraulic pressure ratio of 5.5:1. The HLJ-5X has a lube to hydraulic ratio of 2.2:1. All six models fit either the Modu-Flo pump-to-reservoir mounting manifold or the remote wall mounting manifold.

### FEATURES / BENEFITS

- Adjustable displacement at the turn of a screw provides an infinite choice of outputs within output range of each pump model.
- All Modu-Flo pumps can be used with either oil or grease.
- All Modu-Flo pumps can be used with any of the 23 Modu-Flo reservoirs.

### SPECIFICATIONS

MODEL	ACTUATION	ACTION	DIS-PLACEMENT ADJ. RANGE CU.IN. (CM <sup>3</sup> )	* MAX. CYCLES PER MINUTE	APPROX-IMATE Wt., lb. (kg)	OPERATING VOLUME PER FULL STROKE/CYCLE CU.IN. (CM <sup>3</sup> )
ALS-5	Pneumatic	Single	.010 to .030 (.164 to .492)	65	3.75 (1.7)	1.06 (17.4)
ALJ-5	Pneumatic	Double	.010 to .030 (.164 to .492)	100	3.75 (1.7)	2.09 (34.3)
ALS-25	Pneumatic	Single	.030 to .120 (.492 to 1.966)	25	4.75 (2.15)	4.20 (68.8)
ALJ-25	Pneumatic	Double	.030 to .120 (.492 to 1.966)	100	4.75 (2.15)	8.28 (135.7)
ALS-50	Pneumatic	Single	.060 to .240 (.983 to 3.933)	20	6.5 (2.9)	8.40 (137.6)
ALJ-50	Pneumatic	Double	.060 to .240 (.983 to 3.933)	60	6.5 (2.9)	16.56 (271.4)
<b>NOTE:</b> AL (air) pumps for single- or double-acting operation have the same part number (See page 4.)						
HLJ-5	Hydraulic	Double	.010 to .030 (.164 to .492)	100	3.375 (1.53)	0.35 (5.7)
HLJ-5X	Hydraulic	Double	.030 to .092 (.492 to 1.51)	50	3.375 (1.53)	0.28 (4.7)
HLJ-25	Hydraulic	Double	.030 to .120 (.492 to 1.966)	50	5.5 (2.49)	1.38 (22.6)
<b>NOTE:</b> Min/Max. air pressure for AL pumps is 40 to 150 psi (2.76 to 10.3 bars). Min/Max. hydraulic pressure for HLJ 5 AND 25 pumps is 200 to 2,000 psi (13.8 to 137.9 bars), and 3000 psi (max) (207 bar) for the HLJ-5X. AL Pumps have a lube to air pressure ratio of 30:1. HLJ-5 & 25 Pumps have a lube to hydraulic pressure ratio of 5.5:1. HLJ-5X is 2.2:1. *Do not exceed 10 cpm with grease (3 seconds on, 3 seconds off)						

**Note:** Refer to bulletin 12011 for electric motor operated Modu-Flo pumps.

### OPERATION

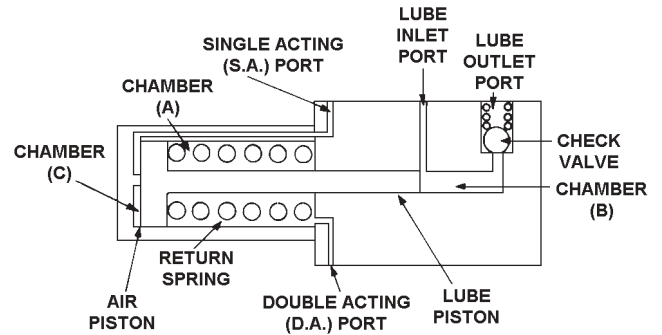

#### Typical Pump Operation

**When used in single-acting mode,** air under pressure is supplied through the inlet port (SA) to chamber (C). This moves the air and lube pistons to the right. This closes the lube inlet port and forces the lubricant already in chamber (B) past the check valve and into the system. Air in chamber (A) must vent out port (DA). A plastic pipe plug with a vent hole is installed in port (DA). After a preset time interval the solenoid valve shuts off the air supply and vents chamber (C) through port (SA). The spring returns the air and lube pistons, opening chamber (B) to the lube reservoir. This completes a single pump cycle and chamber (B) is primed, ready for the next cycle.

**When used in double-acting mode,** an additional air or hydraulic supply line is connected to port (DA). When the pistons have been moved to the right, air or hydraulic supply to port (SA) is shut-off and vented. Then, air or hydraulic fluid under pressure is supplied to port (DA), which returns the pistons to their original position. This more powerful return action allows an increased cycle rate of the pump.

### ADJUSTING DISPLACEMENT

After the pump is removed from service, remove the calibrated cap that protects the adjustment screw. Loosen the hex nut and two washers. Then use a screwdriver to turn the adjustment screw outward to increase displacement or inward to reduce displacement. Align the calibrated cap parallel to the screw to gauge the amount of change (Cap is graduated at minimum, 1/4, 1/2, 3/4 and maximum output). When the proper setting has been made reposition the washers and tighten the hex nut, replace the cap, and return the pump to service.

**Important:** System should **NOT** be operating while adjustments are made; however, it is not necessary to remove the pump or disconnect any lines.



## PUMP DIMENSIONS / Inches (mm)

### PNEUMATIC PUMPS (AL)

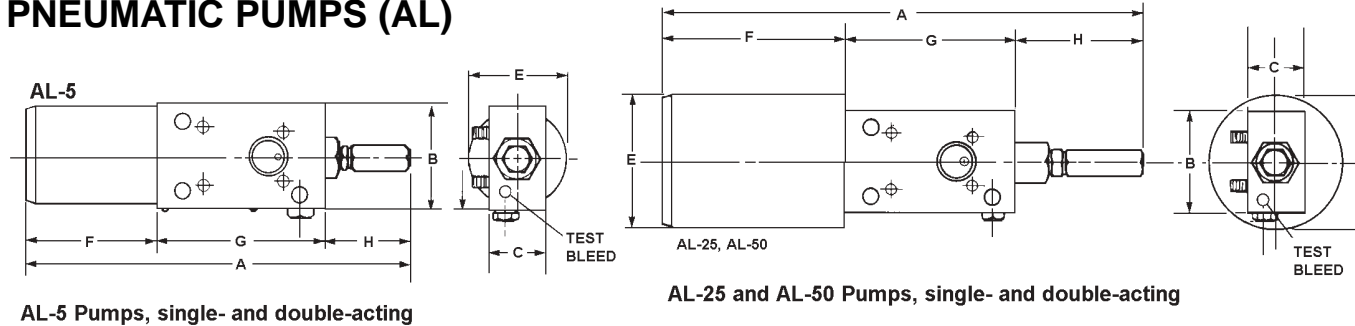

PUMP MODEL	DIMENSIONS / Inches (mm)						
	A	B	C	E	F	G	H
AL-5	8.281 (210.3)	2.250 (57.2)	1.250 (31.8)	2.125 (54)	2.875 (73)	3.656 (92.9)	1.750 (44.5)
AL-25	10.375 (263.5)	2.250 (57.2)	1.250 (31.8)	2.875 (73)	3.980 (101.1)	3.656 (92.9)	2.750 (69.9)
AL-50	12.812 (325.4)	2.250 (57.2)	1.250 (31.8)	3.188 (81)	4.250 (108)	4.808 (122.1)	3.750 (95.3)

### HYDRAULIC PUMPS (HLJ)

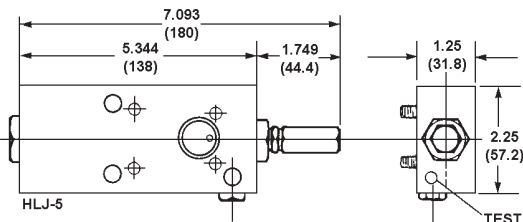

HLJ-5 & HLJ-5X double-acting pump

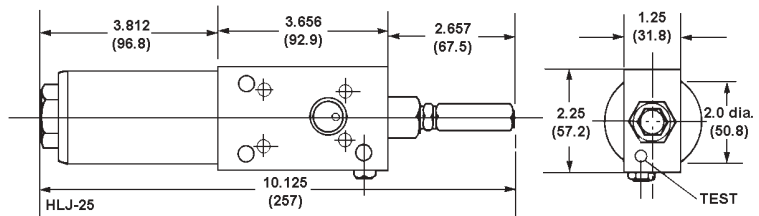

HLJ-25 double-acting pump

## ORDERING INFORMATION

Use the following part numbers only if you are **NOT** ordering a Modu-Flo Lube Package.

**NOTE:** Single- and double-acting pneumatic pumps (AL) have the same part number.

Pump Repair Kits	Part Number
For AL-5, single- or double-acting .....	560-001-021
For AL-25, single- or double-acting .....	560-001-031
For AL-50, single- or double-acting .....	560-001-041
For HLJ-5 .....	560-001-051
For HLJ-25 .....	560-001-061
For HLJ-5X .....	560-001-940

Pump Model	Part Number
AL-5, pneumatic 30:1 ratio (.010-.030 in <sup>3</sup> /stroke) (.164-.492 cc) .....	521-000-001
AL-25, pneumatic 30:1 ratio (.030-.120 in <sup>3</sup> /stroke) (.492-1.966 cc) .....	521-000-021
AL-50, pneumatic 30:1 ratio (.060-.240 in <sup>3</sup> /stroke) (.938-3.933 cc) .....	521-000-041
HLJ-5, hydraulic 5.5:1 ratio (.010-.030 in <sup>3</sup> /stroke) (.164-.492 cc) .....	521-000-011
HLJ-25, hydraulic 5.5:1 ratio (.030-.120 in <sup>3</sup> /stroke) (.492-1.966 cc) .....	521-000-031
HLJ-5X, hydraulic 2.2:1 ratio (.030-.092 in <sup>3</sup> /stroke) (.492-1.51 cc) .....	521-005-900

# Modu-Flo®

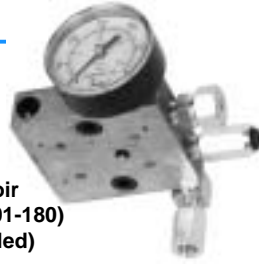

**Pump-to-reservoir manifold (521-001-180)**  
(Shown assembled)

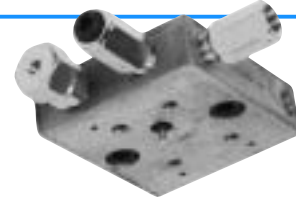

**Pump-to-wall or remote manifold (521-001-170)**  
(Shown assembled)

## MANIFOLDS

There are just two types of modular design manifolds for direct-to-reservoir or remote mounting of Modu-Flo Pumps. Both mount any pneumatic or hydraulic Modu-Flo pump and both types contain all of the pneumatic (or hydraulic) connections and lubricant

lines necessary. This allows the pump to be removed without disturbing existing lines or emptying the reservoir. Also, Modu-Flo manifolds may be used as is, or can be fitted with a choice of matched accessories. (See illustrations and listings that follow.)

## DIMENSIONS / Inches (mm)

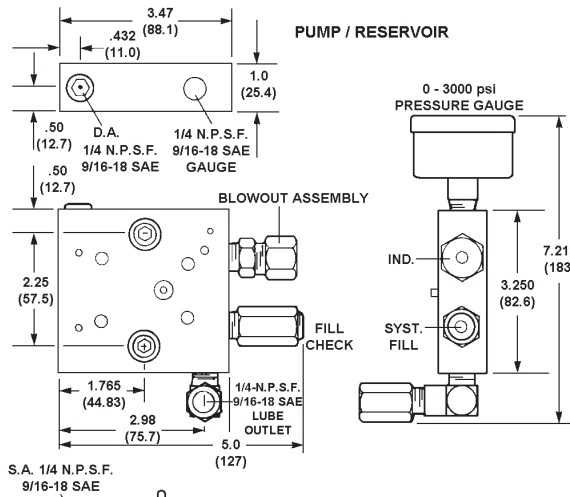

\* Pump-to-reservoir manifold.

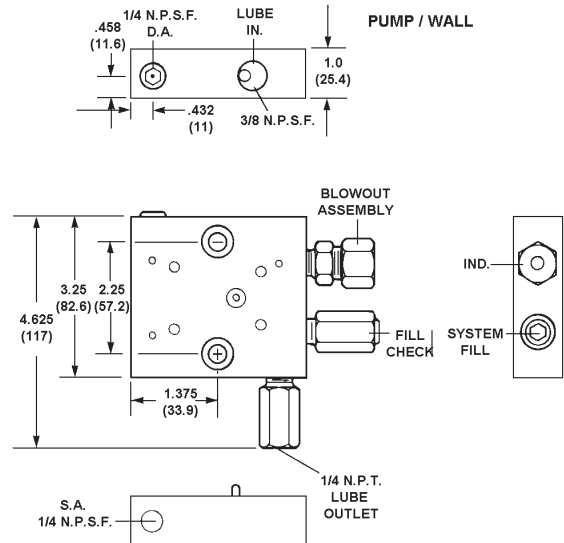

\* Manifold for remote mounting of pump.  
Part Number 521-001-170

## ORDERING INFORMATION

You can order the manifold and accessories you want separately or with one part number, as shown below. If you intend to order the pump, reservoir, manifold and accessories at one time, check the section in this brochure beginning on page 8 titled "Modu-Flo Lube Packages."

### \*\*MANIFOLD/ACCESSORY COMBINATIONS

	PART NUMBER
Pump/Reservoir Manifold only (NPT) .....	521-001-540
Pump/Reservoir Manifold (NPT) .....	521-001-180
Includes outlet check valve, system fill check valve, blowout assembly, and 0-3000 psi pressure gauge.	
Remote Pump Manifold (NPT) .....	521-001-170
Includes outlet check valve, system fill check valve, and blowout assembly.	
Pump/Reservoir Manifold (NPT) with outlet check valve, system fill check valve, tubed blowout assembly, and 0-3000 psi pressure gauge .....	521-001-790
Remote Pump Manifold (NPT) with outlet check valve, system fill check valve, and tubed blowout assembly .....	521-001-780
Pump/Reservoir manifold (SAE) includes outlet check valve, system fill check valve, blowout assembly and pressure gauge .....	521-010-820

**NOTE:** For ratings on spare and/or replacement blowout discs, see page 11.

For other port thread options, contact factory.

### ACCESSORIES FOR MANIFOLD

	PART NUMBER
Outlet Check Valve (NPT) .....	509-360-030
System Fill Check Valve (NPT) .....	509-365-030
Standard Blowout Assembly, 1,450 psi (99.9 bar) (NPT) .....	509-206-100
Tubed Blowout Assembly, 1,450 psi (99.9 bar) (NPT) .....	509-220-101
Standard Pressure Gauge, 3,000 psi (206.9 bar) (NPT) .....	543-363-000
Liquid filled Pressure Gauge, 3,000 psi (206.9 bar) (NPT) .....	543-711-380
Outlet Check Valve (SAE) .....	463-001-587
System Fill Check Valve (SAE) .....	463-001-600
Standard Blowout Assembly, 1,450 psi (99.9 bar) (SAE) .....	509-206-110
Standard Pressure Gauge, 3,000 psi (206.9 bar) (SAE) .....	493-020-242
Gauge Adapter (SAE) 7/16-20 to 9/16-18 .....	412-700-545

\* Manifolds are intended for gravity feed (oil) or spring loaded follower feed (grease) only.

\*\* Manifolds/Accessory combinations are shipped with accessories not assembled to manifold.

# Modu-Flo®



## RESERVOIRS

23 Modu-Flo Reservoirs are available for use with any Modu-Flo Pump or as a separate unit.

They are available in the following configurations and capacities:

- Cylindrical types in plastic and metal are available with grease capacities of 3, 5, 6, 12, 20, and 40 lbs. (1.36, 2.27, 2.72, 5.44, 9.06 and 18.16 kg).
- Cylindrical types in plastic are available with oil capacities of 5, 6, 12 and 20 pints (2.37, 2.84, 5.68 and 9.46 liters).
- Rectangular types in metal are available with oil capacities of 12, 24 and 40 pints (5.58, 11.36 and 18.92 liters).
- Metal reservoirs are equipped with level indicators.

### Modu-Flo RESERVOIR DIMENSIONS / Inches (mm)

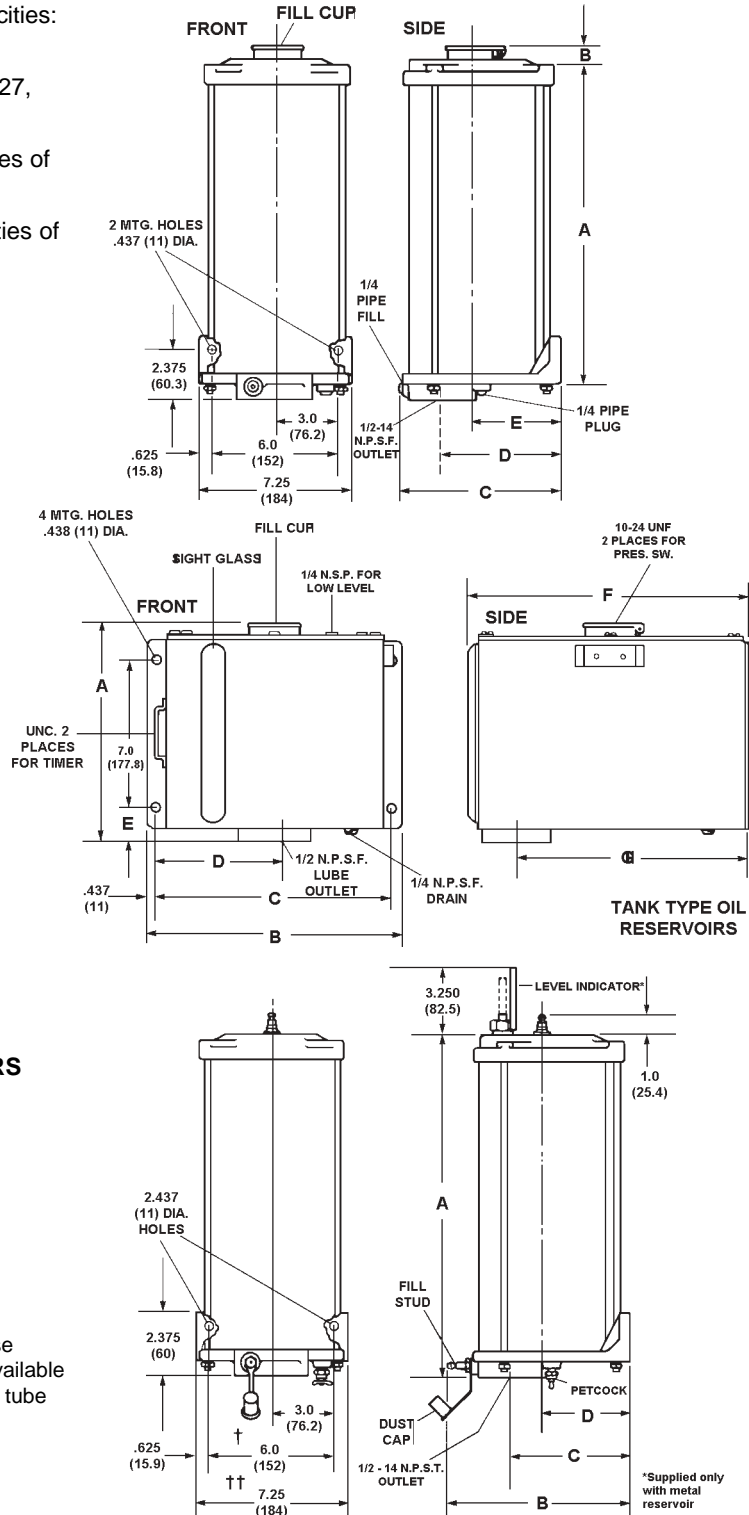

### CYLINDRICAL PLASTIC OIL RESERVOIRS

SIZE	A	B	C	D	E
5-pint	15.00 (381)	.625 (15.9)	5.812 (148)	3.797 (96.4)	3.50 (88.9)
6-pint	10.50 (267)	.750 (19.1)	7.50 (191)	5.625 (143)	4.25 (108)
12-pint	15.00 (381)	.750 (19.1)	7.50 (191)	5.625 (143)	4.25 (108)
20-pint	22.00 (559)	.750 (19.1)	7.50 (191)	5.625 (143)	4.25 (108)

### RECTANGULAR METAL OIL RESERVOIRS (For Larger Capacity Reservoirs, Contact Factory)

SIZE	A	B	C	D	E	F	G
12-pint	10.70 (272)	10.75 (273)	9.875 (251)	5.30 (135)	1.64 (41.7)	7.25 (184)	4.812 (122)
24-pint	10.59 (269)	12.00 (305)	11.125 (283)	5.93 (151)	1.92 (48.8)	13.22 (336)	10.781 (274)
40-pint	10.59 (269)	17.25 (438)	16.375 (416)	6.42 (163)	1.92 (48.8)	13.22 (336)	10.781 (274)

### CYLINDRICAL METAL & PLASTIC GREASE RESERVOIRS

* SIZE	A	B	C	D
3-lb.	6.87 (175)	8.81 (224)	5.62 (143)	4.25 (108)
5-lb.	15 (381)	7.25 (184)	3.62 (92.1)	2.50 (63.5)
6-lb.	10.5 (267)	8.81 (224)	5.62 (143)	4.25 (108)
12-lb.	15 (381)	8.81 (224)	5.62 (143)	4.25 (108)
20-lb.	22 (559)	8.81 (224)	5.62 (143)	4.25 (108)
40-lb.	22.6 (574)	9.12 (232)	7.2 (183)	

\*See Note 3, Page 12.  
 †7.5" (190) 40 lbs.  
 ††9.0" (229) 40 lbs.  
 40 lbs. Cylindrical grease reservoir (not shown) available with fiberglass reservoir tube only.

Metal grease reservoir illustrated at right

# RESERVOIR ACCESSORIES

## LOW-LEVEL SWITCHES

All reservoirs are available with a lubricant low-level switch accessory for fault diagnosis or fault warning. These devices are single-pole, double-throw limit switches rated at 15 amps, 125, 250 or 480 VAC 60/50 Hz...1/2 amp at 125 VDC...and 1/4 amp at 250 VDC. An optional 'low-watt' single-pole, single-throw, 10-watt low-level switch is available for oil reservoirs (See page 10 for dimensions of low watt switches).

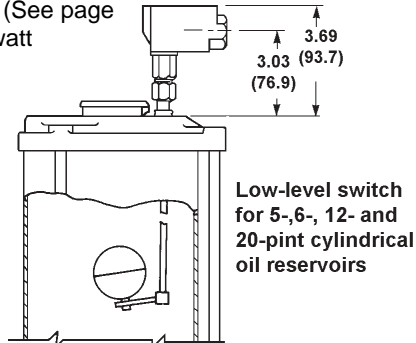

### SUPPORT BRACKET

When mounting a 12 lb. or 20 lb. cylindrical reservoir to equipment that vibrates, a support bracket is available to secure the top of the reservoir.

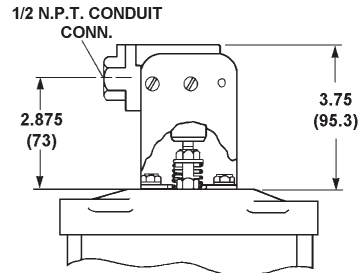
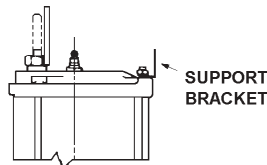

Low-level switch for 5-, 6-, 12-, and 20-pound cylindrical grease reservoirs

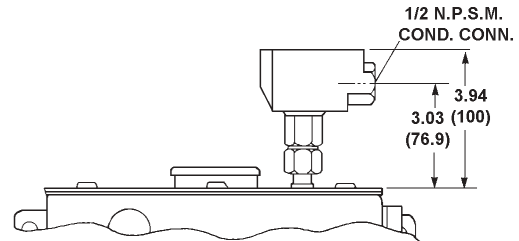

Low-level switch assembly for 12-, 24- and 40-pint rectangular (tank) reservoirs.

## PRESSURE INDICATORS

There are pressure switches for all Modu-Flo reservoirs, plus a selection of high pressure blowouts. For part numbers, see ordering information below. For details, see page 10 of this brochure.

## ORDERING INFORMATION

Use the part number at right to order the reservoir you require.

FOR OIL	PART NUMBER
5-pint capacity, plastic, cylindrical .....	185-100-080
6-pint capacity, plastic, cylindrical .....	185-100-750
12-pint capacity, plastic, cylindrical .....	185-100-060
20-pint capacity, plastic, cylindrical .....	185-100-070
12-pint capacity, metal, rectangular .....	521-001-060
24-pint capacity, metal, rectangular .....	521-001-760
40-pint capacity, metal, rectangular .....	521-001-080
*FOR GREASE	PART NUMBER
3-lb. capacity, plastic, cylindrical .....	185-101-080
3-lb. capacity, plastic, cylindrical with low level switch actuator (see note 5 page 12) .....	185-101-140
5-lb. capacity, plastic, cylindrical .....	185-100-040
6-lb. capacity, plastic, cylindrical .....	185-100-760
12-lb. capacity, plastic, cylindrical .....	185-100-000
20-lb. capacity, plastic, cylindrical .....	185-100-010
40-lb. capacity .....	185-100-970
40-lb. capacity with visual level .....	185-100-980
40-lb. capacity with low level switch .....	185-101-130
Oil units with screw on fill/breather (not shown)	
6-pt with low level switch .....	185-101-020
12-pt. with low level switch .....	185-101-000
20-pt. with low level switch .....	185-101-010
5-lb. capacity, metal, cylindrical .....	185-100-050
6-lb. capacity, metal, cylindrical .....	185-100-770
12-lb. capacity, metal, cylindrical .....	185-100-020
20-lb. capacity, metal, cylindrical .....	185-100-030
Fill coupler for grease reservoir .....	506-322-000
* See Note 3, Page 12	

SUPPORT BRACKET	PART NUMBER
Oil 12- and 20-pint Cylindrical reservoirs .....	521-001-130
Grease, 12- and 20lb. cylindrical reservoirs .....	521-001-130

LOW-LEVEL SWITCH ASSEMBLIES	PART NUMBER
Oil, 5- and 12-pint cylindrical reservoirs, S.P.D.T., 15 amp .....	521-001-030
Oil, 20-pint cylindrical reservoirs, S.P.D.T., 15 amp .....	521-001-040
Oil, 6-pint cylindrical and all tank reservoirs, S.P.D.T., 15 amp .....	521-001-050
Oil, 5- and 12-pint cylindrical reservoirs, S.P.S.T., 10 watt .....	456-010-172
Oil, 20-pint cylindrical reservoir, S.P.S.T., 10 watt .....	456-010-173
Oil, 6-pint cylindrical and all tank reservoirs, S.P.S.T., 10 watt .....	456-010-171
Grease, 5-, 6-, 12- and 20-lb. cylindrical reservoirs .....	521-001-110

PRESSURE SWITCH ASSEMBLIES	PART NUMBER
Pressure Switch for all reservoirs .....	542-210-120
High Pressure Blowout for 5-pint or 5-lb. capacity reservoirs .....	521-001-190
High Pressure Blowout for 12- and 20-pint or 12- and 20-lb. capacity reservoirs .....	521-001-200
High Pressure Blowout for all rectangular reservoirs .....	521-001-210

# Modu-Flo®

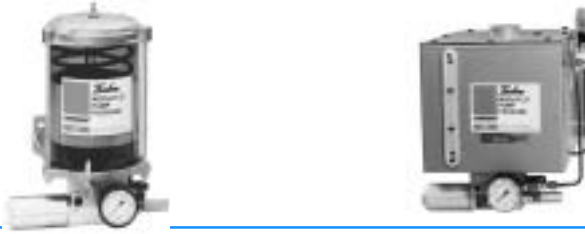

## LUBE PACKAGES

Available in a broad selection of pump-manifold-reservoir combinations with a choice of modular, matched accessories - order the complete package with a single part number.

Modu-Flo Lube Packages can be provided with any of three pneumatic or three hydraulic pumps...utilize modular manifolds...supply oil or grease from any of 23 reservoirs for either lubricant. There is also a range of accessories that brings the package up to the exact degree of automation or system diagnostic capability that your application requires.

For ordering guidance, see the data on this and the following pages in this brochure; then use the ordering menu on the back cover.

### Accessory options for Modu-Flo Lube Package include:

- Low-level options
- Pressure switch options
- Solid-State A-C timer
- Solenoid option
- Wiring option

Also, Modu-Flo Lube Packages can be interfaced with a choice of Trabon and Lubriquip controllers with varying ranges of functions or interfaced with other systems. . . or monitored and directed by host controllers and diagnostic Systems. For more information about this type of installation and Modu-Flo units for it, consult the factory.

## TYPICAL MODU-FLO LUBE PACKAGE FOR OIL

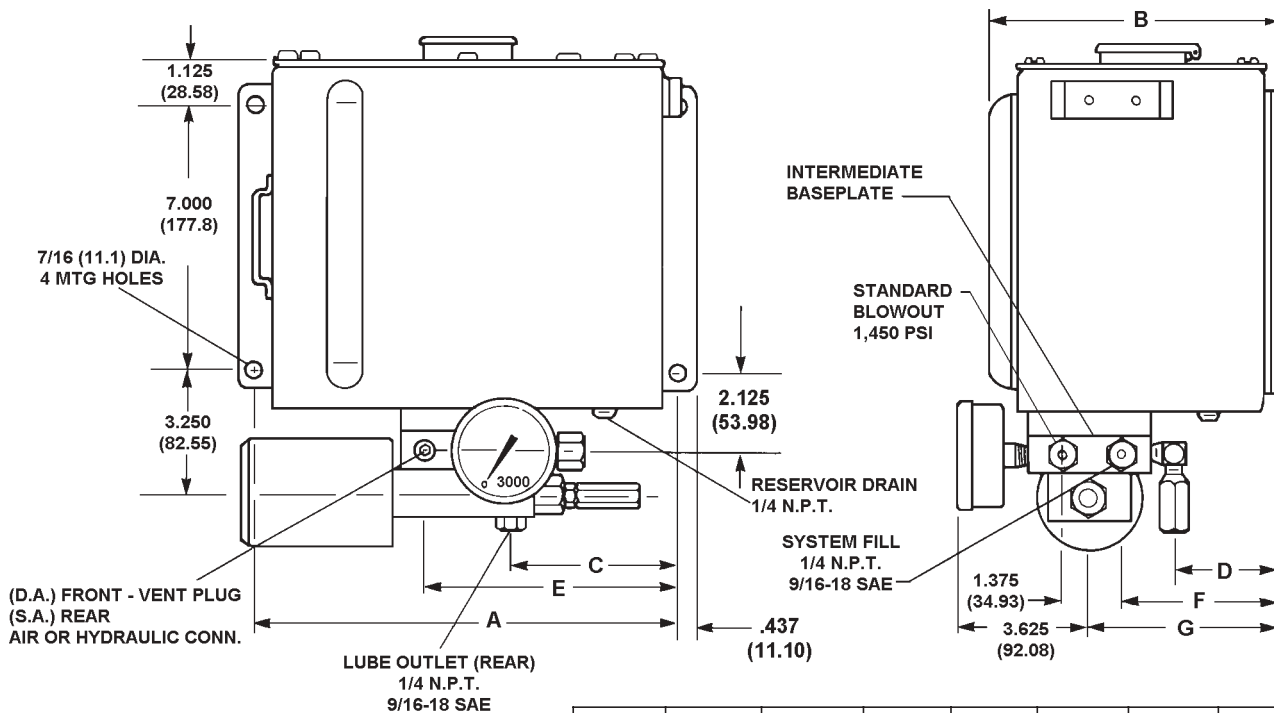

For larger capacity reservoirs, contact factory.

SIZE	A	B	C	D	E	F	G
12-pint	9.875 (250.83)	7.250 (184.15)	3.718 (94.44)	2.375 (60.33)	6.312 (160.32)	4.062 (103.17)	4.750 (120.65)
24-pint	11.125 (282.58)	13.218 (335.737)	4.343 (110.33)	8.375 (212.73)	7.750 (196.85)	10.062 (255.57)	10.750 (273.05)
40-pint	16.375 (415.93)	13.218 (335.737)	6.968 (177.01)	8.375 (212.73)	9.500 (241.3)	10.062 (255.57)	10.750 (273.05)



# TYPICAL LUBE PACKAGE CHOICES AVAILABLE FOR OIL OR GREASE SYSTEMS UTILIZING PNEUMATIC OR HYDRAULIC POWER.

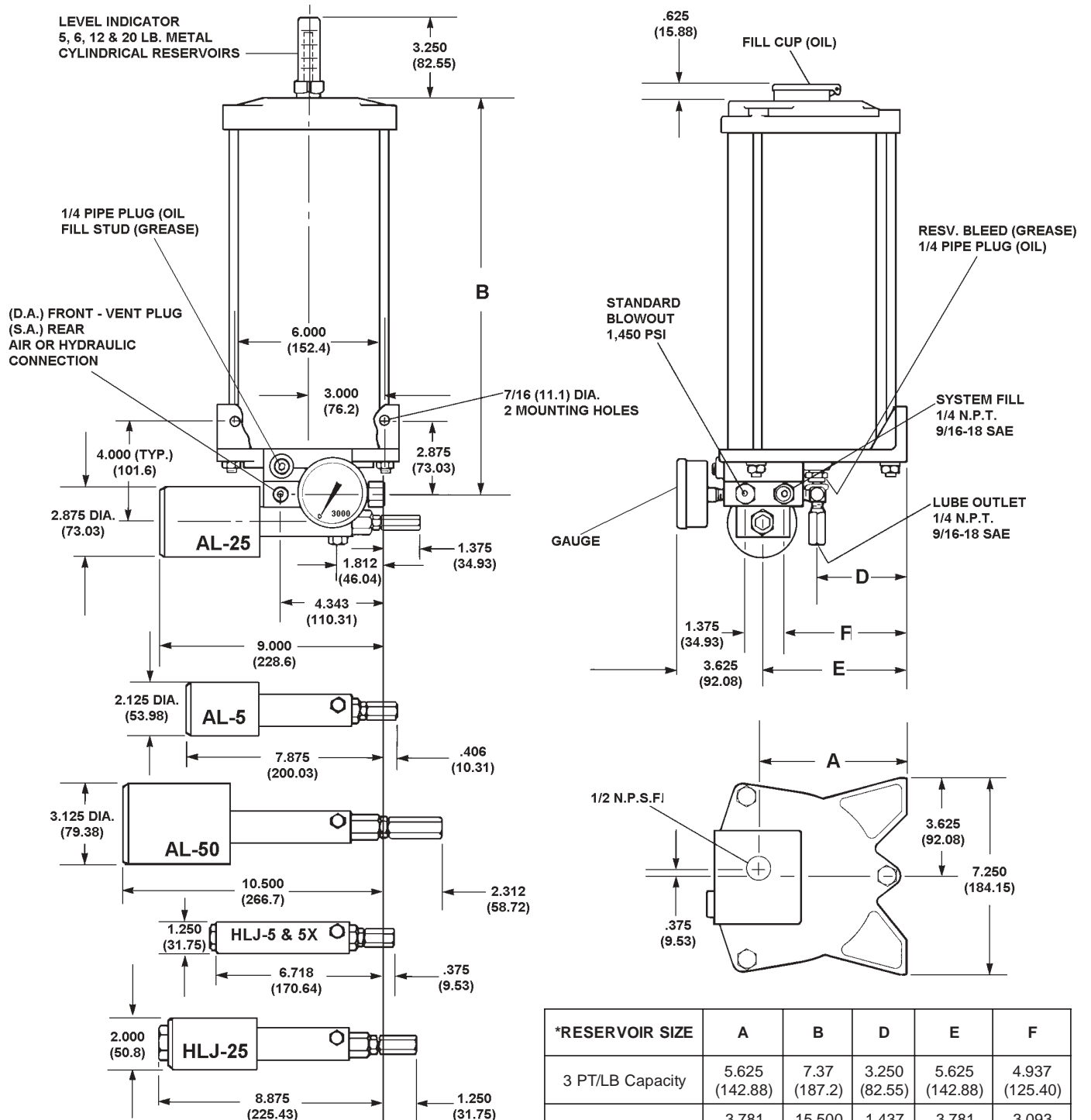

NOTES:  
 (1) If application requires a filler vent plug, order Part No. 540-117-000.  
 (2) For extra blowout discs, order Part No. 560-900-270.

\*See Note 3, Page 12

*RESERVOIR SIZE	A	B	D	E	F
3 PT/LB Capacity	5.625 (142.88)	7.37 (187.2)	3.250 (82.55)	5.625 (142.88)	4.937 (125.40)
5 PT/LB Capacity	3.781 (96.04)	15.500 (393.7)	1.437 (36.50)	3.781 (96.04)	3.093 (78.56)
6 PT/LB Capacity	5.625 (142.88)	11.000 (279.4)	3.250 (82.55)	5.625 (142.88)	4.937 (125.40)
12 PT/LB Capacity	5.625 (142.88)	15.500 (393.7)	3.250 (82.55)	5.625 (142.88)	4.937 (125.40)
20 PT/LB Capacity	5.625 (142.88)	22.500 (571.5)	3.250 (82.55)	5.625 (142.88)	4.937 (125.40)

# Modu-Flo®

## LUBE PACKAGE ACCESSORIES

### PRESSURE PROTECTION

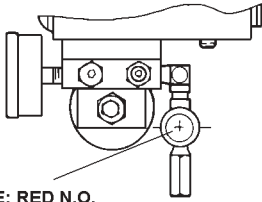

5 FT. 3 WIRE CABLE: RED N.O.  
BLACK N.C.  
WHITE COMMON

Oil pressure switch is factory set at 1,150 (79.3 bar). However, it is field adjustable from 400 to 4,700 psi (27.6 to 324 bar). For all Modu-Flo reservoirs, it is rated 5 amps @ 115/230 VAC... 3 amps @ 30 VDC inductive load and 5 amps @ 30 VDC resistive load. It is option P1 on the menu.

High pressure blowout switch options are single-pole, double-throw type and rated 20 amps @ 125, 250 and 480 VAC... 1/2 amp @ 125 VDC, and 1/4 amp @ 250 VDC. For 5-pound or 5-pint capacity cylindrical reservoirs, specify Option P2.

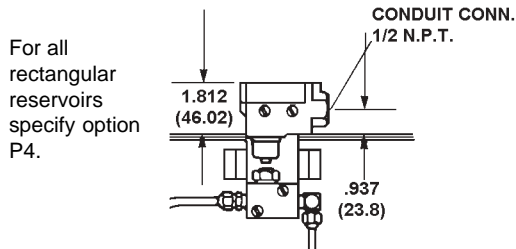

For all rectangular reservoirs specify option P4.

For 6-, 12- and 20-pound or 6-, 12- and 20-pint capacity cylindrical reservoirs, specify option P3.

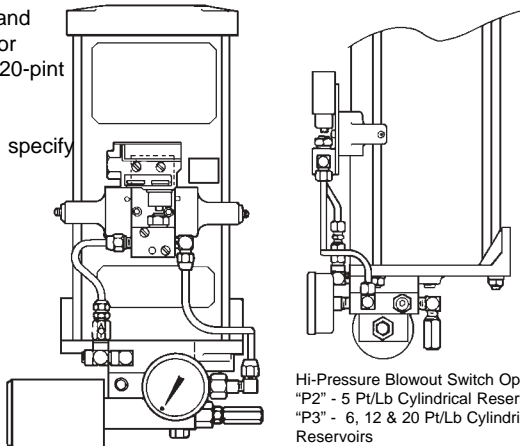

Hi-Pressure Blowout Switch Option "P2" - 5 Pt/Lb Cylindrical Reservoirs  
"P3" - 6, 12 & 20 Pt/Lb Cylindrical Reservoirs

### LOW-LEVEL PROTECTION

Modular low-level switch assemblies are all single-pole, double-throw type rated 20 amps @ 125, 250 and 480 VAC 60/50 Hz... 1/2 amp @ 125 and 1/4 amp @ 250 VDC. An optional "low-watt" single-pole, single-throw, 10-watt low-level switch is available for oil reservoirs.

Low-level switch assembly for use with 5- and 12-pint capacity cylindrical oil reservoirs is option L1 on the ordering menu on the back cover of this brochure. A low-level switch assembly for the 20-pint capacity cylindrical reservoir is option L2.

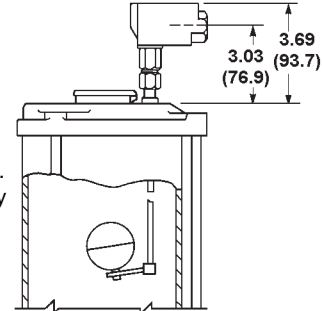

Low-level switch assembly for 12-, 24- and 40-pint capacity rectangular tank and the 6-pint cylindrical oil reservoir is option L3.

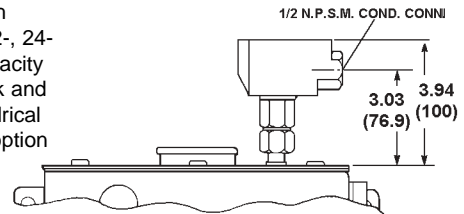

Low-level switch option for all grease reservoirs (except 3lb and 40lb) is option L4

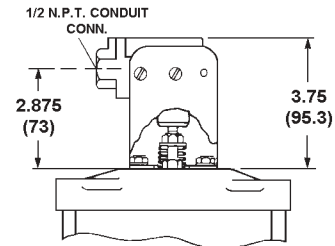

"Low-watt" low-level switch assembly for 5- and 12-pint capacity plastic cylindrical reservoirs is option L5.

"Low-watt" low-level switch assembly for 20-pint capacity plastic cylindrical oil reservoir is option L6.

"Low-watt" low-level switch assembly for 12-, 24- and 40-pint capacity rectangular tanks and 6-pint cylindrical oil reservoir is option L7.

"Low-watt" dual level switch assembly. (Low and low shutdown) for 12, 24 and 40 pint capacity rectangular tanks is option L8.

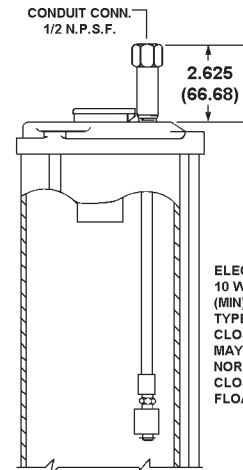

ELECTRIC RATING:  
10 WATTS @ 120 VAC.  
(MIN) S.P.S.T. REED  
TYPE SWITCH NORMALLY  
CLOSED (HELD OPEN).  
MAY BE CONVERTED TO  
NORMAL OPEN (HELD  
CLOSED) BY INVERTING  
FLOAT.

## SOLID STATE AC TIMER OR STROKE COUNTER

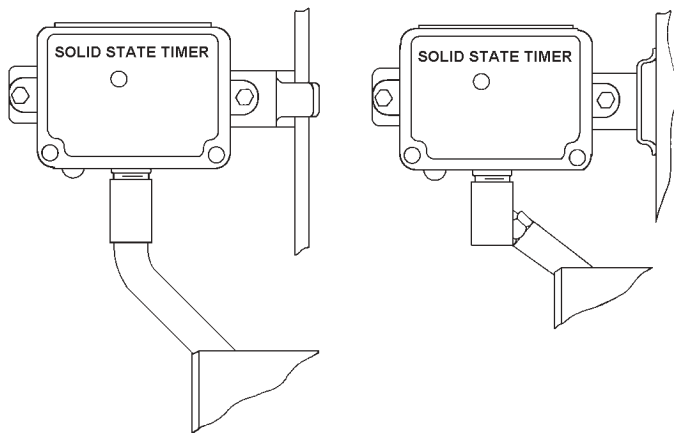

The Solid State Timer utilizes 110/220 VAC 60/50 Hz input, and permits total cycle times to be set at any period from 30 seconds to 32 hours. “On” time during total cycle time can be set from 12 seconds to 13 minutes, and takes place at the beginning of each period. For data sheet on timer, see Lit. No 14521.

The Stroke Counter programs the operation of a lubrication system using machine cycles or strokes rather than time. It energizes a load that initiates the lubrication system each time the machine cycles through the number of strokes preset on the stroke setting dial. It is especially suited to equipment which operates on variable duty cycle. See Lit. No. 14522 for details.

### SOLENOID VALVE OPTION

110/120 VAC, 0.11A in-rush, 0.07A holding; 24 VDC, 8.5 W

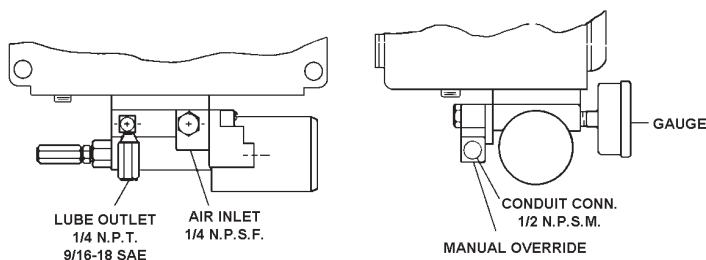

Valve is 115 VAC, 3-way, pneumatic, normally closed with a manual override button to simplify system testing, line filling and line bleeding. It is option S1 on menu. A 24 VDC version is also available. It is Option S2 on menu.

### WIRING OPTIONS

When you specify a Modu-Flo Lube Package with solenoid and control options, you can also order the wiring option (the solenoid valve wired to the controller) from the menu. This option, however, is available only when ordering Modu-Flo Lube Packages.

## SPARE OR REPLACEMENT BLOWOUT DISCS FOR PRESSURE PROTECTION

PSI (bar)*		COLOR CODE	PART NUMBER
900	(62.0)	Black	509-290-000
1,175	(81.0)	Green	509-291-000
1,450	(99.9)	Yellow	509-292-000
1,750	(120.7)	Red	509-293-000
2,050	(141.4)	Orange	509-294-000
2,350	(162)	Aluminum	509-295-000
2,650	(182.6)	Pink	509-296-000
2,950	(203)	Blue	509-297-000
3,250	(220.1)	Purple	509-298-000

\* Discs up to 2,350 psi have a tolerance of ± 500 psi. Discs greater than 2,350 psi have a tolerance of ± 20%.

## SOPHISTICATED CONTROL

Look to Lubriquip for the ideal controller to meet your system requirements and your budget limitations.

We offer the broadest line of units available in the centralized lubrication systems field. Our controllers range from simple, very economical single-count and multiple-count controllers... to microprocessor-based multi-function monitor/controllers. Recently, we've pioneered a new concept in modularly packaged, factory programmed controllers that are customized to your needs—at a fraction of the complexity and the cost of the programmable controllers now being offered to industry.

For details, contact your Trabon / Lubriquip distributor or consult the factory.

## OPERATION/SERVICE

For operation and service instructions on Modu-Flo components, refer to Trabon bulletin 42000.

PACKAGE ORDER INFORMATION (MENU)

MPP-XXX-XXX-XX-XX-XX-XX-XXX-XX

RESERVOIR OPTION:

- OP1 - 5 PINT OIL CYLINDRICAL PLASTIC (185-100-080)
- OP2 - 12 PINT OIL CYLINDRICAL PLASTIC (185-100-060)
- OP3 - 20 PINT OIL CYLINDRICAL PLASTIC (185-100-070)
- OP4 - 6 PINT OIL CYLINDRICAL PLASTIC (185-100-750)
- T1- 12 PINT OIL TANK (521-001-060)
- T2 - 24 PINT OIL TANK (521-001-070)
- T3 - 40 PINT OIL TANK (521-001-080)
- GP1 - 5 LB. GREASE CYLINDRICAL PLASTIC (185-100-040)
- GP2 - 12 LB. GREASE CYLINDRICAL PLASTIC (185-100-000)
- GP3 - 20 LB. GREASE CYLINDRICAL PLASTIC (185-100-010)
- GP4 - 6 LB. GREASE CYLINDRICAL PLASTIC (185-100-760)
- GP5 - 3 LB. GREASE CYLINDRICAL PLASTIC (185-101-080) (see footnote 5)
- GM1 - 5 LB. GREASE CYLINDRICAL METAL (185-100-050)
- GM2 - 12 LB. GREASE CYLINDRICAL METAL (185-100-020)
- GM3 - 20 LB. GREASE CYLINDRICAL METAL (185-100-030)
- GM4 - 6 LB. GREASE CYLINDRICAL METAL (185-100-770)

BASEPLATE THREAD OPTION:

NPT - INTERMEDIATE BASEPLATE (521-001-180) FOR OTHER THREAD OPTIONS, CONTACT FACTORY. SAE INTERMEDIATE BASEPLATE 521-010-820

\*PUMP OPTION:

- A0 - NONE
- A1 -ALS - 5 (521-000-001) AIR, S.A., 30:1 RATIO (.010 - .030 IN<sup>3</sup>/STROKE)
- A2 - ALJ - 5 (521-000-001) AIR, D.A.
- A3 - ALS - 25 (521000-021) AIR, S.A., 30:1 RATIO (.030 - .120 IN<sup>3</sup>/STROKE)
- A4 - ALJ - 25 (521-000-021) AIR, D.A.
- A5 - ALS - 50 (521-000-041) AIR, S.A., 30:1 RATIO (.060 - .240 IN<sup>3</sup>/STROKE)
- A6 - ALJ - 50 (521-000-041) AIR, D.A.
- H1 - HLJ - 5 (521-000-011) HYDR, D.A., 5.5:1 RATIO (.010 - .030 IN<sup>3</sup>/STROKE)
- H2 - HLJ - 25 (521-000-031) HYDR, D.A., 5.5:1 RATIO (.030 - .120 IN<sup>3</sup>/STROKE)
- H3 - HLJ - 5X (521-005-900) HYDR, D.A., 2.2:1 RATIO (.030 - .092 IN<sup>3</sup>/STROKE)
- E3 - (521-007-220) 24VDC W/O ADJ., (SEE FOOTNOTE 4)
- E4 - (521-007-240) 24VDC W/O ADJ., W/TIMER (SEE FOOTNOTE 4)
- E5 - (521-007-060) 115VAC W/O ADJ., (SEE FOOTNOTE 4)

\*PRESSURE GAUGE OPTION:

- G1 - NO GAUGE
- G2 - 3000 PSI STANDARD GAUGE (543-362-000)
- G3 - 3000 PSI LIQUID FILL GAUGE (543-711-380)

\*LOW LEVEL OPTION:

- L1 - 5 AND 12 PINT CYLINDRICAL OIL RESERVOIR - S.P.D.T. 15 AMP (521-001-030)
- L2 - 20 PINT CYLINDRICAL OIL RESERVOIR - S.P.D.T. 15 AMP (521-001-040)
- L3 - 12, 24 & 40 PINT TANK AND 6 PINT CYLINDRICAL OIL RESV. - S.P.D.T. 15 AMP (521-001-050)
- L4 - ALL GREASE RESERVOIRS EXCEPT 3LB & 40 LB (521-001-110)
- L5 - 5 AND 12 PINT CYLINDRICAL OIL RESERVOIR - S.P.S.T. 10 WATTS (456-010-172)
- L6 - 20 PINT CYLINDRICAL OIL RESERVOIR - S.P.S.T. 10 WATTS (456-010-173)
- L7 - 12, 24 & 40 PINT TANK AND 6 PINT CYLINDRICAL OIL RESV. - S.P.S.T. 10 WATTS (456-010-171)
- L8 - 12, 24 & 40 PINT TANK DUAL SPST, 10 WATT SWITCH (ONE LOW, ONE LOW SHUTDOWN) 456-020-951

\*PRESSURE INDICATOR OPTION:

- P1 - PRESSURE SWITCH ALL SIZES (542-210-120)
- P2 - HIGH PRESSURE BLOWOUT SWITCH 5 PT/LB CYLINDRICAL (521-001-190)
- P3 - HIGH PRESSURE BLOWOUT SWITCH 6,12 & 20 PT/LB CYLINDRICAL (521-001-200)
- P4 - HIGH PRESSURE BLOWOUT SWITCH ALL TANKS (521-001-210)
- P5-STANDARD BLOWOUT- 1,450 PSI (509-206-100)

\*SOLENOID VALVE OPTION (NOT AVAILABLE WITH SAE BASEPLATE):

- S1 - 115 V., 3-WAY PNEUMATIC SOLENOID VALVE (521-001-020)
- S2 - 24 VDC 3-WAY PNEUMATIC SOLENOID VALVE (521-002-100)

\*TIMER/CONTROLLER:

- C10 - SOLID-STATE A-C TIMER ALL TANKS (521-004-500)
- C11 - SOLID-STATE A-C TIMER 5 PT/LB CYLINDRICAL (521-004-510)
- C12 - SOLID-STATE A-C TIMER 6, 12 & 20 PT/LB CYLINDRICAL (521-004-520)
- C13 - SOLID-STATE STROKE COUNTER ALL TANKS (521-004-740)
- C14 - SOLID-STATE STROKE COUNTER 5 PT/LB CYLINDRICAL (521-004-750)
- C15 - SOLID-STATE STROKE COUNTER 6, 12, & 20 PT/LB CYLINDRICAL (521-004-760)

\*WIRING OPTION:

- W1 - SOLENOID VALVE WIRED TO TIMER OR COUNTER
- \*OMIT WHEN NOT REQUIRED



© Registered trademark of LUBRIQUIP, INC., A Unit of IDEX Corporation, Printed in U.S.A.

- NOTES:
- (1) If application requires a filter vent plug, order Part No. 540-117-000
  - (2) For extra blowout discs. Order Part No. 560-900-270
  - (3) Nominal grease reservoir size is based on a direct conversion of oil reservoir capacity and does not reflect volume loss due to the follower and spring. Actual volumes contained are: 5 & 6 lb (2.6 lb), 12 lb (5.8 lb), 20 lb (11.8 lb)
  - (4) Reference Bulletin 12011 for electric Modu-Flo pump specifications
  - (5) 3-lb with low level switch actuator 185-101-140 (Order switch and bracket 510-599-000 separate)