

Vickers®

# Piston Pumps

---



## PVH Piston Pumps

High flow, high performance pumps  
for industrial and mobile applications

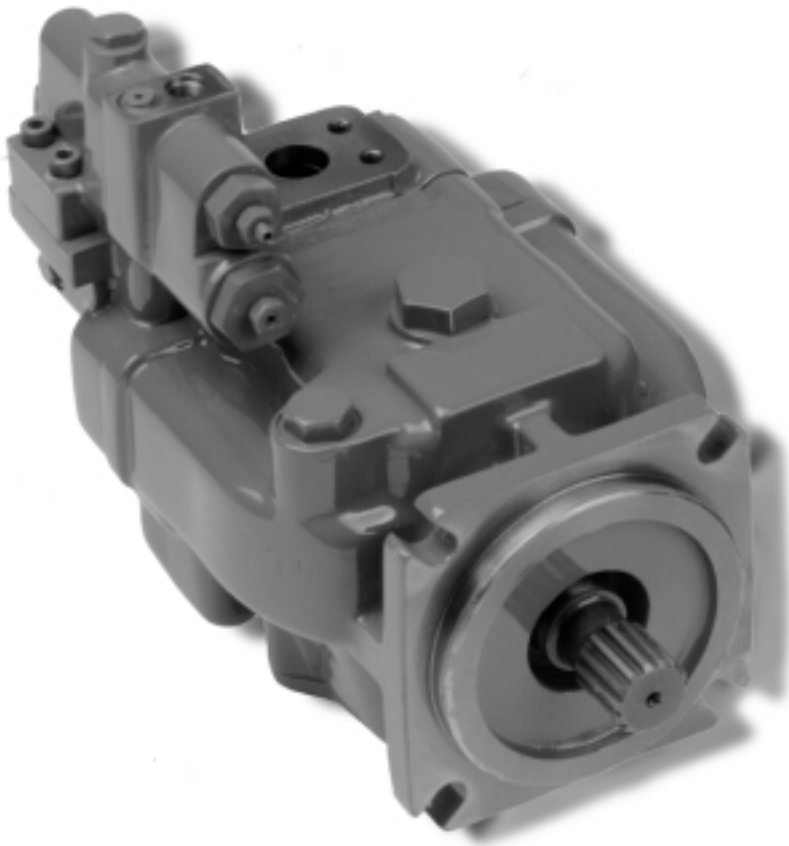

# Introduction

---

PVH high flow, high performance pumps are a family of variable displacement, inline piston units that incorporate the proven design, quality manufacturing techniques and operating features of other Vickers piston pumps, but in a smaller, lighter package.

The PVH series has been specially designed to meet the 250 bar (3625 psi) continuous duty performance requirements of new generation equipment designs.

These are efficient, reliable pumps, with a selection of optional controls for maximum operational flexibility. Designed specifically for strenuous application, they provide the productivity gains and controllability improvements desired in earthmoving, construction, machine tool, plastics, and all other energy-conscious markets. As with all Vickers products, these pumps have been fully laboratory tested and field proven.

## PVH Series Benefits

---

- Versatile design includes single pumps, thru-drive arrangements, and a variety of drive shaft and control options that will adapt to any application and provide the most cost effective installation.
- Proven components designed into a heavy duty, compact housing to provide 250 bar (3625 psi) continuous operating performance, and 280 bar (4050 psi) operating performance in a load sensing system. This design assures long life at the higher performance levels required of today's power-dense machinery.
- Compact and lightweight design to reduce the application weight, and provide better access for installation and servicing.
- Service kits developed for the most critical rotating and control components to simplify and assure successful pump servicing.
- Quiet designs available for noise-sensitive industrial applications, reducing sound levels further to provide a more acceptable environment.
- Designed for maximum efficiency in any type of application. A variety of compensators provide the most effective system control, and the 95%-plus volumetric efficiency means more flow, and more input energy, is directed to the work and not into heat and waste.
- Heavy duty bearings and shafts result in minimum internal deflections and wear, providing for longer life and maximum uptime.

# Table of Contents

---

<b>Model Codes</b> .....	4
<b>Performance Data</b>	
Rated characteristics .....	5
Performance curves .....	6
Response data .....	9
Sound levels .....	9
<b>Control Options</b>	
Pressure compensator .....	10
Load sensing and pressure compensator .....	10
Remotely controllable pressure compensator with load sensing option .....	11
Pressure and torque limiter control .....	12
Pressure and torque limiting plus load sensing .....	13
<b>Input Shaft Selection Data</b> .....	14
<b>Input Shaft Dimensions</b> .....	15
<b>Installation Dimensions</b>	
Basic pumps (non-thru-drive) .....	16
Adjustable maximum volume stop .....	20
Thru-drive pumps .....	21
ISO pump mounting flange .....	24
Combination 2-bolt/4-bolt SAE pump mounting flange .....	24
Rear cover for thru-drive pump .....	24
Pumps for shaft-up operation .....	25
Foot mounting kit .....	25
<b>Application Data</b>	
Hydraulic fluids and temperature ranges .....	26
Fluid cleanliness .....	26
Drive data .....	26
<b>Weights, Ordering, Installation and Start-up</b> .....	27

# Model Codes

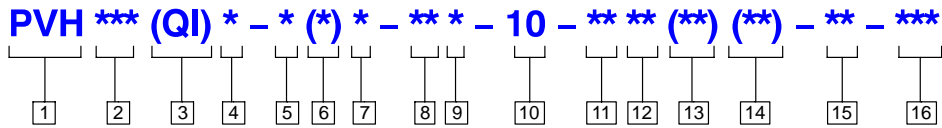

- 1 Pump series**
- 
- 2 Maximum geometric displacement**  
 57 = 57,4 cm<sup>3</sup>/r (3.5 in<sup>3</sup>/r)  
 74 = 73,7 cm<sup>3</sup>/r (4.5 in<sup>3</sup>/r)  
 98 = 98,3 cm<sup>3</sup>/r (6.0 in<sup>3</sup>/r)  
 131 = 131,1 cm<sup>3</sup>/r (8.0 in<sup>3</sup>/r)
- 
- 3 Design/application**  
 Blank = Design for mobile applications  
 QI = Quiet design for industrial applications
- 
- 4 Mounting flange, prime mover end**  
 C = SAE "C" 4-bolt type (SAE J744-127-4)  
 M = ISO 3019/2-125B4HW (Option for PVH57 and PVH only. Must use "N" shaft.)
- 
- 5 Shaft rotation, viewed at prime mover end**  
 R = Right hand (clockwise)  
 L = Left hand (counterclockwise)
- 
- 6 Configuration**  
 Blank = Non-thru-drive (single pump)  
 A = Thru-drive pump with SAE "A" 2-bolt rear flange mounting (SAE J744-82-2)  
 B = Thru-drive pump with SAE "B" 2- and 4-bolt rear flange mountings † (SAEJ744-101-2/4)  
 C = Thru-drive pump with SAE "C" 2- and 4-bolt rear flange mountings † (SAEJ744-127-2/4)  
 S = Adjustable maximum volume stop (non-thru-drive and non-torque-control models only)

† Built from pump with SAE "A" rear pad to which suitable flange adapter is bolted. For best availability and flexibility, order PVH SAE "A" thru-drive pump and SAE "B" or "C" adapter kit separately. ( See page 23.)

- 7 Main ports**  
 F = SAE 4-bolt flange ports  
 M = SAE 4-bolt flange ports with metric mounting bolt threads
- 
- 8 Shaft-end type, at prime mover end**  
 (See torque limits on page 14 and shaft dimensions on page 15.)  
 N = ISO 3019/2-E32N short straight keyed (Must use "M" mtg. flg.)  
 1 = SAE "C" straight keyed (J744-32-1)  
 2 = SAE "C" splined 14 tooth 12/24 D.P. (J744-32-4)  
 3 = SAE "CC" splined 17 tooth 12/24 D.P. (J744-38-4)  
 12 = SAE "D" splined 13 tooth 8/16 D.P. (J744-44-4)  
 13 = SAE "CC" straight keyed (J744-38-1)  
 16 = SAE "D" straight keyed (J744-44-1)
- 
- 9 Shaft seal, prime mover end**  
 S = Single, one-way.  
 D = Double, two-way. Recommended on second pump of tandem assembly (PVH\*\*/ PVH\*\*) and "wet mount" applications.
- 
- 10 Pump design number**  
 10 (Subject to change. Installation dimensions unaltered for design numbers 10 to 19 inclusive.)
- 
- 11 Pressure compensator and adjustment range**  
 C = 70-250 bar (1015-3625 psi)  
 CM = 40-130 bar ((580-1885 psi)  
 IC = Industrial control, 20 bar (290 psi) differential pressure setting (QI models only)

Note: Unloading valve controls for accumulator circuits are available. See your Vickers representative for circuit review and approval.

- 12 Pressure compensator factory setting in tens of bar**  
 25 = Normal factory setting of 250 bar (3625 psi) for "C" models.  
 7 = Normal factory setting of 70 bar (1015 psi) for "CM" models.
- 
- 13 Additional control functions**  
 Blank = No additional controls  
 V = Load sensing, 20 bar (290 psi) differential pressure setting  
 T = Torque limiter  
 VT = Load sensing and torque limiter
- 
- 14 Torque limiter factory setting**  
 (Use with "T" and "VT" above)  
 \*\* = Customer desired torque limiter setting specified in ten bar (145 psi) increments, e.g.:  
 8 = 80 bar (1160 psi);  
 18 = 180 bar (2610 psi).
- 
- 15 Control design number**  
 31 = C, CM, C\*\*V, or IC controls  
 13 = C\*\*T controls  
 14 = C\*\*VT controls
- 
- 16 Special features suffix**  
 027 = Composite 2-bolt/4-bolt mounting conforming to SAE "C" (except PVH131)  
 031 = Thru-drive SAE "A" pad cover  
 041 = No case-to-inlet relief valve (for use with supercharged circuits). 3,4 bar (50 psi) maximum inlet pressure  
 057 = Shaft-up operation (vertical mount)

# Performance Data

Performance data is typical with SAE 10W anti-wear hydraulic oil at 50° C (120° F) and at zero pump inlet pressure, except where otherwise indicated.

## Rated Characteristics of PVH\*\*\*QI Industrial Pumps

Parameters	PVH57QI	PVH74QI	PVH98QI	PVH131QI
Geometric displacement, max.				
cm <sup>3</sup> /r	57,4	73,7	98,3	131,1
(in <sup>3</sup> /r)	(3.5)	(4.5)	(6.0)	(8.0)
Rated pressure				
bar (psi)	250 (3625) †	250 (3625) †	250 (3625) †	250 (3625) †
Rated speeds in r/min at various inlet pressures				
127 mm Hg (5" Hg)	1500	1500	1500	1200
Zero inlet pressure	1800	1800	1800	1500
0,48 bar (7 psi)	1800	1800	1800	1800
Typical effective flow in l/min (USgpm) at 250 bar (3625 psi)				
at 1500 r/min	83 (22)	102 (27)	140 (37)	186 (49)
at 1800 r/min	98 (26)	125 (33)	170 (45)	223 (59)

† In load sensing systems the compensator can be set at 280 bar (4060 psi).

## Ratings of PVH\*\*\*QI Industrial Pumps with Alternate Fluids

Parameters	Petroleum based	Polyol ester	Water glycol	HWBF(90–10) thickened
Max. pressure				
bar (psi)	250 (3625)	230 (3300)	172 (2500)	155 (2250)
Max. speed in r/min at:				
1,0 bar abs. (0 psi)	1800 ‡	1800	1800	1700
0,85 bar abs. (5" Hg)	1500 □	1500	1500	1500
Max. inlet temp.				
deg. C (deg. F)	93 (200)	65 (150)	50 (120)	50 (120)

‡ 1500 rpm for PVH131 only.

□ 1200 rpm for PVH131 only.

## Rated Characteristics of PVH\*\*\* Mobile Pumps ◇

Parameters	PVH57	PVH74	PVH98	PVH131
Rated speeds in r/min at various inlet pressures				
127 mm Hg (5" Hg)	2000	1850	1750	1650
Zero inlet pressure	2400	2200	2100	2000
0,48 bar (7 psi)	3000	2750	2600	2500
Typical effective flow in l/min (USgpm) at 250 bar (3625 psi) and rated speed @				
zero inlet pressure	134 (35)	156 (41)	202 (53)	249 (66)

◇ Displacements & rated pressure are same as for PVH\*\*\*QI industrial pumps.

# Performance Data

## PVH57

Delivery and efficiency versus outlet pressure at 1800 r/min

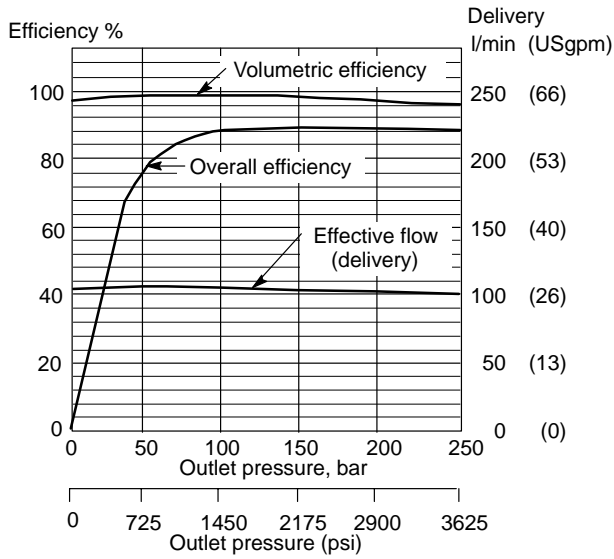

Input torque and power versus outlet pressure at 1800 r/min

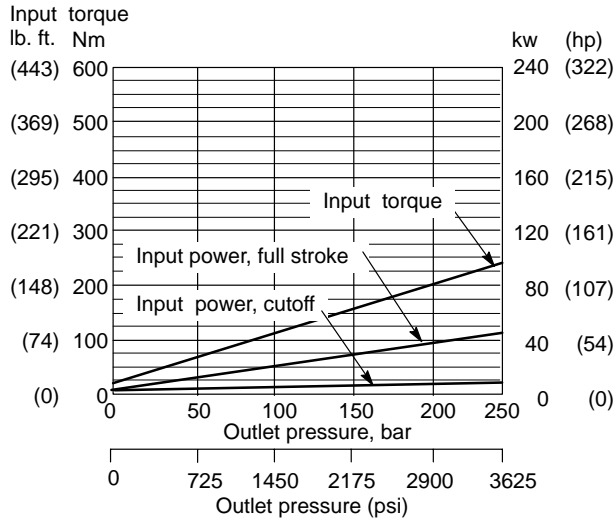

Input power versus speed

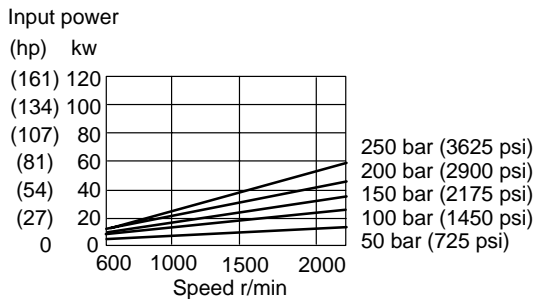

## PVH74

Delivery and efficiency versus outlet pressure at 1800 r/min

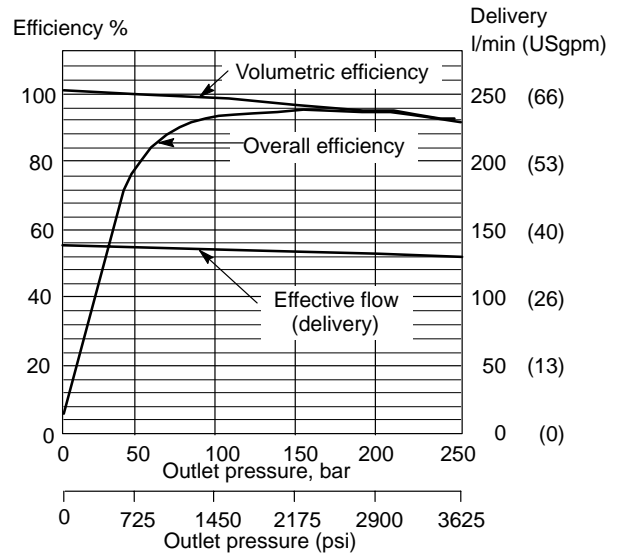

Input torque and power versus outlet pressure at 1800 r/min

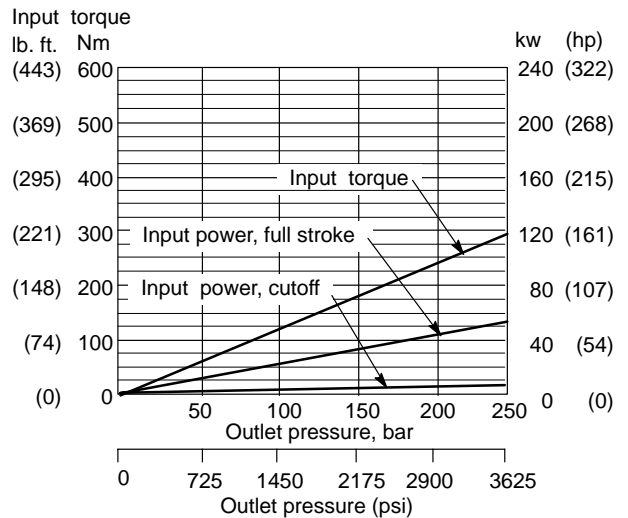

Input power versus speed

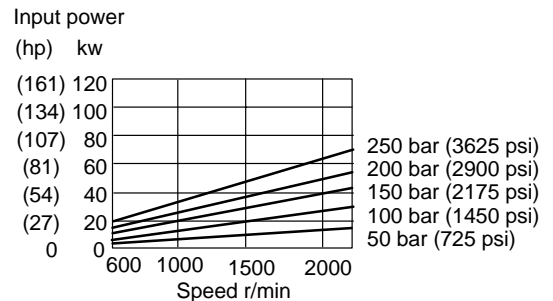

# Performance Data

## PVH98

Delivery and efficiency versus outlet pressure at 1800 r/min

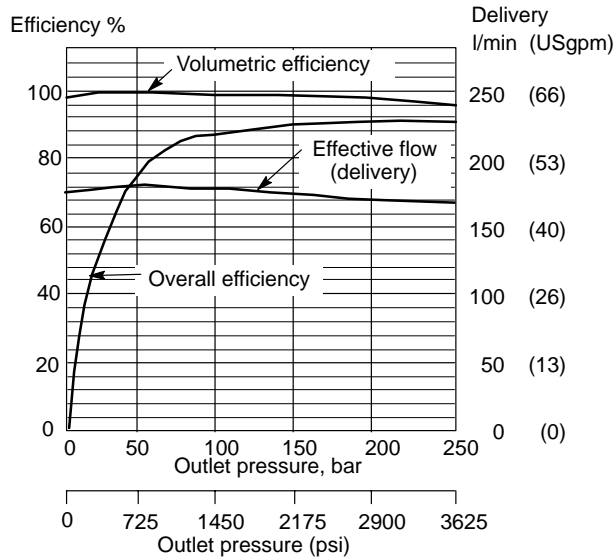

Input torque and power versus outlet pressure at 1800 r/min

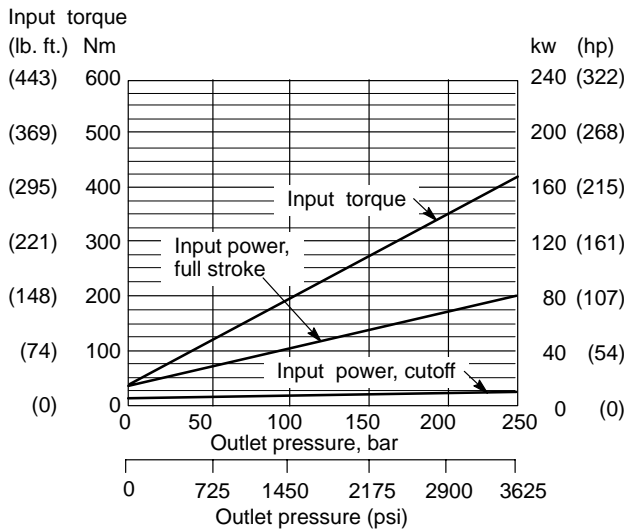

Input power versus speed

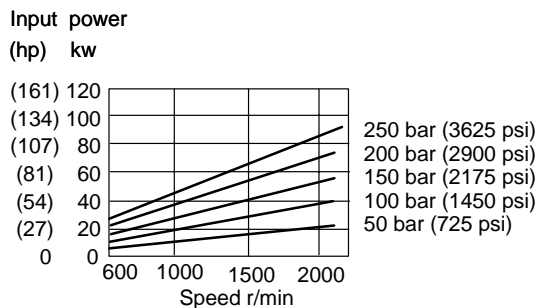

## PVH131

Delivery and efficiency versus outlet pressure at 1800 r/min

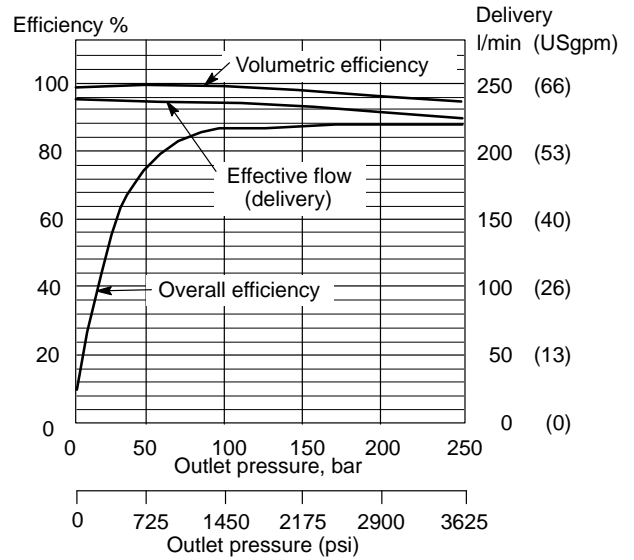

Input torque and power versus outlet pressure at 1800 r/min

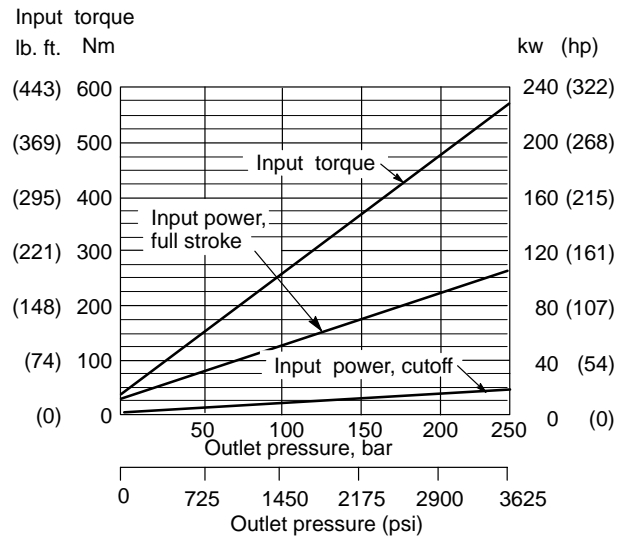

Input power versus speed

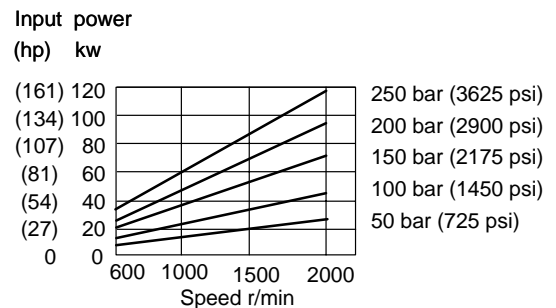

# Performance Data

Performance data is typical with SAE 10W anti-wear hydraulic oil at 50° C (120° F) and at zero pump inlet pressure, except where otherwise indicated.

## Rated Speed at Reduced Displacement and Zero Inlet Pressure

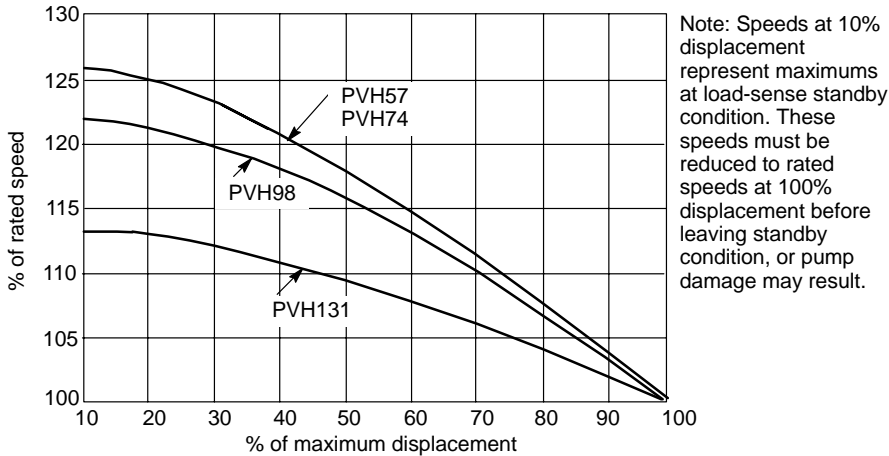

## Effective Flow at Maximum Torque

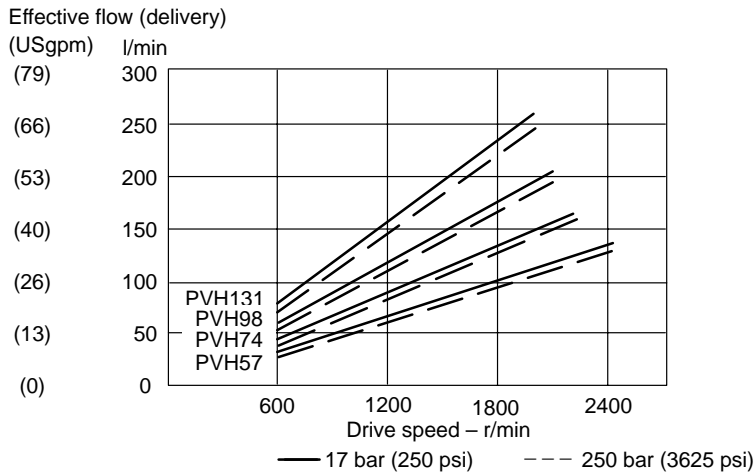

## Inlet Pressure/Vacuum versus Speed, Non-QI Models

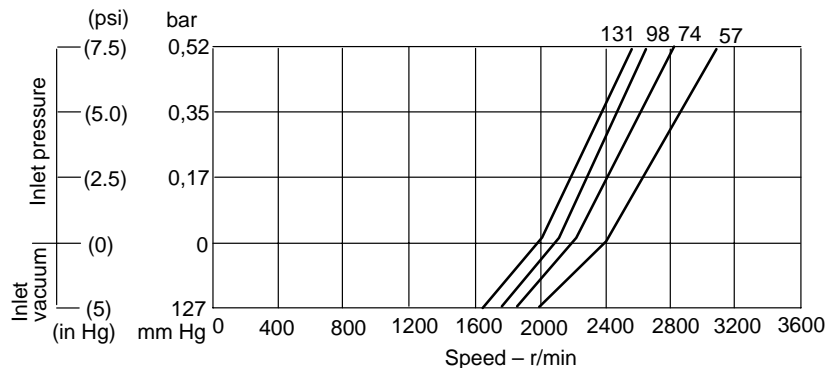



# Performance Data

## Response Data

Model series/ Control type	Typical yoke response †	
	On stroke	Off stroke
PVH57/C**	.101 sec.	.015 sec.
PVH57/C**V	.080 sec.	.014 sec.
PVH74/C**	.097 sec.	.015 sec.
PVH74/C**V	.088 sec.	.028 sec.
PVH98/C**	.134 sec.	.019 sec.
PVH98/C**V	.118 sec.	.029 sec.
PVH131/C**	.139 sec.	.019 sec.
PVH131/C**V	.118 sec.	.029 sec.

† Based on 6900 bar/sec (100,000 psi/sec) pressure rise at rated speed and pressure.

## Sound Levels

Vickers PVH pumps are designed to provide the highest levels of system performance with noise levels within OSHA requirements. The standard models exhibit low sound levels across a wide range of operating speeds and pressures to accommodate the conditions necessary for high performance mobile vehicles. In addition, the quieter QI models provide even lower sound levels at typical in-plant conditions.

Sound is generated by a variety of factors associated with the system, machine, and environment. For more information concerning the causes and nature of noise in machinery, and methods to reduce sound levels, refer to Vickers' "More Sound Advice" bulletin 390 and "Noise Control in Hydraulic Systems" bulletin 510.

## Mobile Version – Sound Level dB(a) DIN (NFPA) ‡

Pressure bar (psi)	PVH57		PVH74		PVH98		PVH131	
	1200 r/min	1800 r/min	1200 r/min	1800 r/min	1200 r/min	1800 r/min	1200 r/min	1800 r/min
70 (1015)	69 (71)	75 (76)	69 (71)	74 (76)	69 (71)	73 (75)	74 (76)	78 (82)
140 (2030)	74 (76)	76 (78)	74 (76)	76 (78)	71 (74)	76 (78)	79 (81)	85 (87)
210 (3025)	75 (77)	79 (81)	75 (77)	79 (81)	75 (77)	80 (82)	81 (88)	87 (89)
250 (3625)	75 (77)	79 (81)	75 (77)	79 (81)	76 (78)	82 (84)	81 (83)	88 (90)

## Industrial Version – Sound Level dB(a) DIN (NFPA) ‡

Pressure bar (psi)	PVH57QI		PVH74QI		PVH98QI		PVH131QI	
	1200 r/min	1800 r/min	1200 r/min	1800 r/min	1200 r/min	1800 r/min	1200 r/min	1800 r/min
70 (1015)	62 (64)	69 (71)	63 (65)	71 (73)	67 (69)	73 (75)	73 (75)	78 (80)
140 (2030)	64 (66)	71 (73)	67 (69)	73 (74)	68 (70)	74 (76)	75 (77)	82 (84)
210 (3025)	68 (70)	74 (76)	71 (73)	75 (77)	73 (75)	78 (80)	79 (80)	85 (87)
250 (3625)	69 (71)	76 (78)	71 (73)	76 (78)	75 (77)	80 (82)	80 (82)	87 (89)

‡ DIN: Computed semi-anechoic values per DIN 45635. NFPA: Recorded in a semi-anechoic chamber in accordance with NFPA Recommended Standard 13.9.70.12. All values shown are the higher of either maximum displacement or fully compensated conditions.

**Due to the rounding of numbers during conversion, the difference between DIN and NFPA ratings may be one or two numbers; for example 69 (71) or 69 (72).**

# Control Options

## C or CM Pressure Compensator Control

The pump will provide a continuously modulated flow to meet changing load demands at a pre-adjusted compensator pressure. At pressures below the compensator setting, the pump will operate at maximum displacement. The compensator is available in two pressure ranges. The “C” spring has an adjustment range of 70–250 bar (1015–3625 psi). The “CM” spring has an adjustment range of 40–130 bar (580–1885 psi).

### C or CM Control

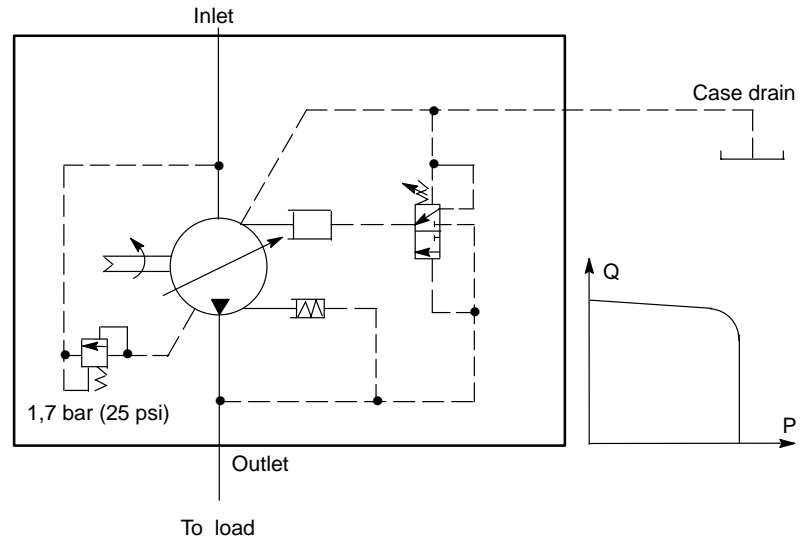

## C(M)\*V Load Sensing and Pressure Compensator Control

The pump will provide power matching of pump output to system load demand, maximizing efficiency and improving load metering characteristics of any directional control valve installed between the pump and the load.

Load sensing ensures that the pump always provides only the amount of flow needed by the load. At the same time, the pump operating pressure adjusts to the actual load pressure plus a pressure differential required for the control action. When the system is not demanding power, the load sense control will operate in an energy-saving stand-by mode.

### C\*\*V or CM\*V Control

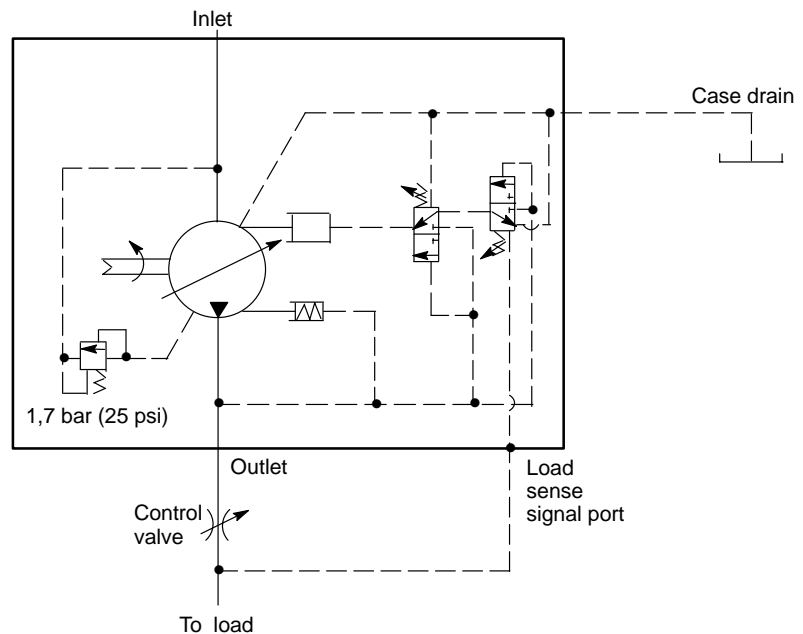

Typically, the differential pressure is that between the pressure inlet and service port of a proportionally controlled directional valve, or a load sensing directional control valve. The standard differential pressure setting for load sense is 20 bar (290 psi), but can be adjusted to between 17 and 30 bar (247 and 435 psi) on the pump.

If the load pressure exceeds the system pressure setting, the pressure compensator de-strokes the pump. The load sensing line must be as short as possible and can also be used for remote control or unloading of the pump pressure. For remote control purposes, it is recommended that you contact your Vickers representative for the correct configuration of the control.

# Control Options

## Pump with IC Compensator

This pump is intended for use when multiple, remote, or electrically controlled compensating settings, with or without load sensing, are desired.

Pressure compensation is obtained when an internal plug is removed, the load-sense signal port is kept plugged, and internal pilot pressure is applied to the spring chamber of the control spool. For pressure compensation with load sensing, the internal plug stays, the load-sense signal port is unplugged, and pilot pressure is externally applied.

An external relief valve (not supplied) controls spring chamber pressure. The externally adjustable spring determines the differential pressure setting of the control. Outlet pressure is limited to the value of the spring chamber (pressure port) pressure, plus control differential pressure.

Spring chamber (pilot) pressure is separated from outlet pressure by an internal orifice. Outlet pressure shifts the spool when pressure drop across the orifice reaches the differential pressure setting, and the pump de-strokes.

The relief valve can be mounted to an NFPA-D03/ISO 4401-03 pad on the pump control, or remotely located via tapping and blanking plates installed on the pad. See "Ordering Procedure", page 27, for more on valves and plates.

The standard factory-set differential pressure setting of the pump control is 20 bar (290 psi) and is not specified in the pump model number. Any other ordered differential pressure, within the control's adjustable pressure range of 17–35 bar (247–508 psi), will be specified in the model number following the "IC" control code; for example, "-IC30-" for a 30 bar setting.

## IC Compensator

### Pressure Compensating Without Load Sensing

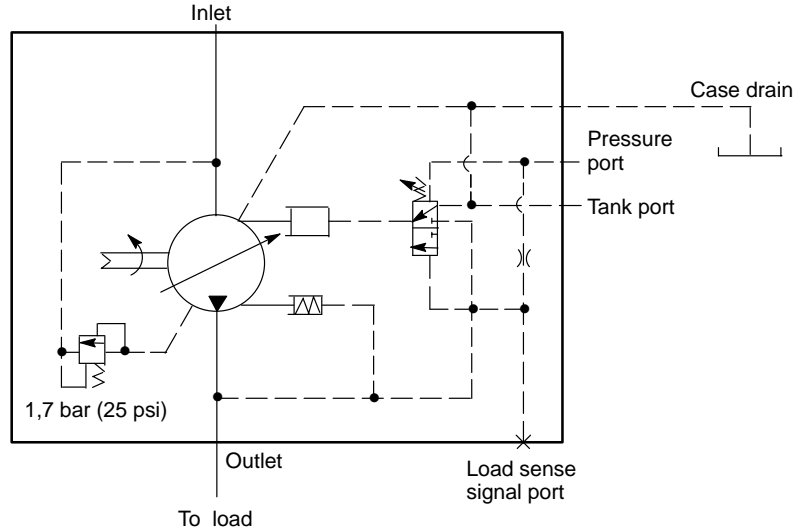

### Pressure Compensating with Load Sensing

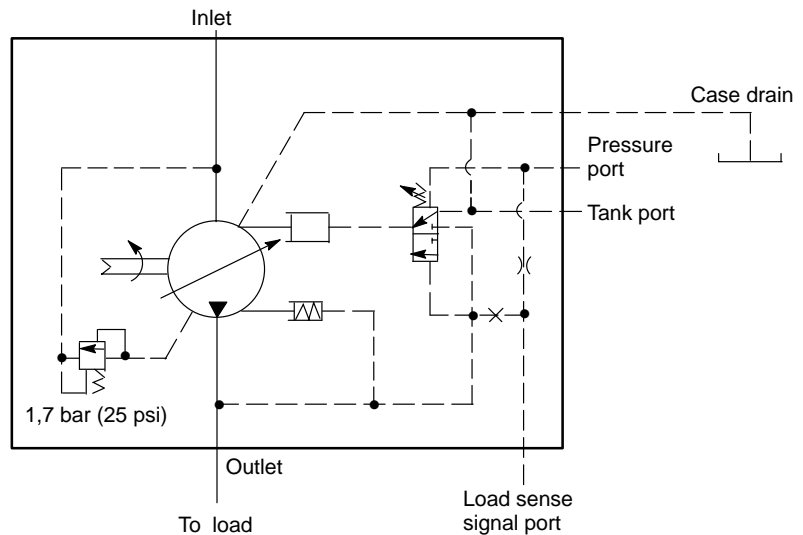

# Control Options

## C\*\*T Pressure and Torque Limiter Control

The pump senses pressure and flow and starts destroking at a predetermined input torque level. The rate of flow reduction is normally tailored to follow the maximum power capability curve of the prime mover. Input torque is limited while the pressure compensator limits the system pressure.

When the input speed remains constant (i.e. industrial drives), the torque limiter acts as an input power limiter. This allows a smaller electric motor to be used if maximum pressure and maximum flow are not required at the same time. At low load levels, the control permits high pump displacement and high load speeds. Under heavy loads, speed is reduced, preventing stalling of the prime mover. In the case of variable speed drives (I.C. engines), this function provides, in addition to pressure compensation or limiting, a torque limiting ability that can be adjusted to the torque/speed characteristics of the engine.

The start of torque limiting (pump-destroking) is pressure dependent. This pressure is selectable (see model code) and is factory preset to between 30% and 80% of the maximum pressure control setting. The minimum torque pressure setting is 40 bar (580 psi). Example: C10T4. There is no "CM" spring option available with the torque limiting control.

## C\*\*T Control

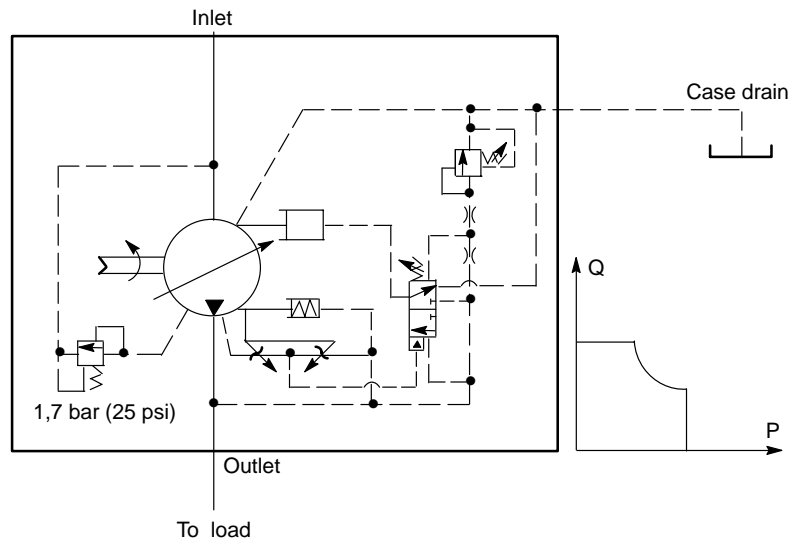

# Control Options

## C\*\*VT Pressure and Torque Limiting, Plus Load Sensing, Control

The pump's control functions like a load sensing control, but with additional torque limiting tailored to the size of the drive motor selected. The limiting function is the same as for a pressure compensator with torque limiting (see C\*\*T description, previous page). The combination of the two controls provides the following benefits:

1. The energy savings of a variable displacement load sensing control.
2. The pump pressure follows the load pressure.
3. The torque control allows smaller drive motors to be used.
4. The pressure compensator de-strokes the pump as maximum pressure is reached.
5. The pump pressure can also be remotely controlled using the load sense line. The C\*\*VT control allows complete control of flow and pressure, either mechanically or electrically, if used with proportional valves.

## C\*\*VT Control

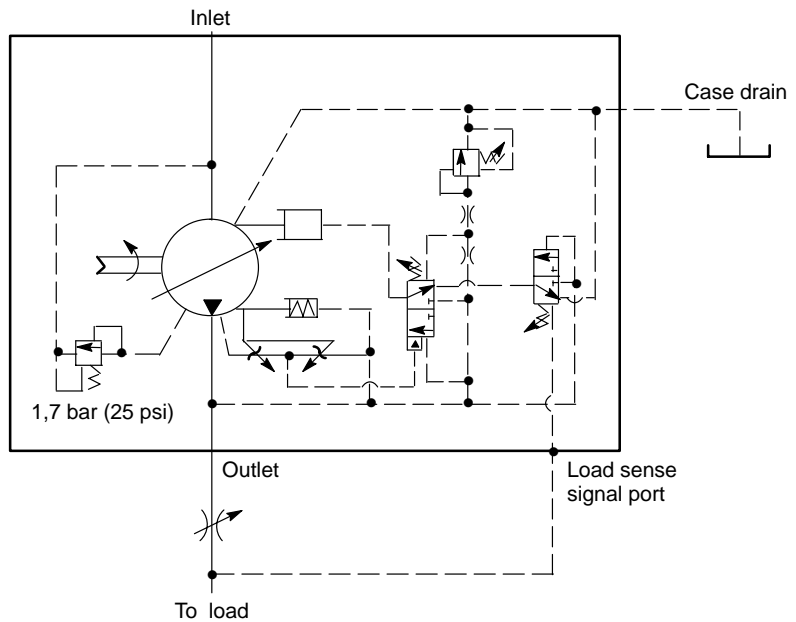

# Input Shaft Selection Data

Multiple pump arrangements can be formed by a PVH thru-drive pump and any suitable pump (single or multiple) that can be installed on the SAE "A", "B", or "C" rear-mounting option available for the thru-drive pump.

It is important to check that maximum torque values for individual pump sections, or complete pumps, occurring in a specific application will not exceed the limits tabled below.

Shaft code	Shaft designation	Basic pump series	Thru-drive pump series	Maximum input torque Nm (lb. in.)	Maximum thru-drive output torque Nm (lb. in.)
N	ISO 3019/2–E32N short straight keyed	PVH57	–	450 (3,980)	–
		PVH74	–	450 (3,980)	–
1	SAE "C" (J744-32-1) straight keyed	PVH57	PVH57	450 (3,980)	335 (2,965)
		PVH74	–	450 (3,980)	–
		PVH98	–	450 (3,980)	–
2	SAE "C" (J744-32-4) 14T 12/24 DP FRSF spline	PVH57	PVH57	640 (5,660)	335 (2,965)
		PVH74	–	640 (5,660)	–
		PVH98	–	640 (5,660)	–
3	SAE "CC" (J744-38-4) 17T 12/24 DP FRSF spline	–	PVH74	1215 (10,750)	460 (4,070)
		–	PVH98	1215 (10,750)	640 (5,660)
		PVH131	PVH131	1215 (10,750)	640 (5,660)
12	SAE "D" (J744-44-4) 13T 8/16 DP FRSF spline	PVH131	PVH131	1215 (10,750)	640 (5,660)
13	SAE "CC" (J744-38-1) straight keyed	–	PVH74	765 (6,770)	460 (4,070)
		–	PVH98	765 (6,770)	460 (4,070)
		PVH131	–	765 (6,770)	–
16	SAE "D" (J744-44-1) straight keyed	–	PVH131	1200 (10,620)	640 (5,660)

Note: Any deviation from maximum input torques must be approved by Vickers. To assure developed thru-drive loads are within PVH pump limitations, actual torque values must not exceed values shown.

# Input Shaft Dimensions

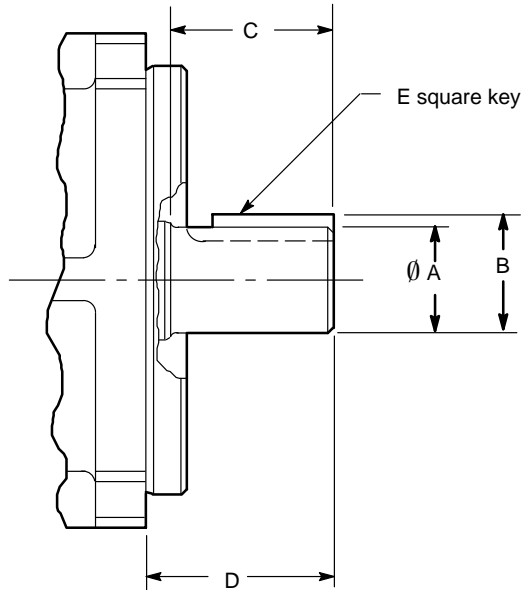

## Straight Keyed Shafts\*

Shaft code	Shaft designation	A	B	C	D	E
1	SAE "C" (J744-32-1)	31,75 (1.25)	35,32 (1.38)	48,0 (1.89)	56,0 (2.20)	7,93 (.312)
13	SAE "CC" (J744-38-1)	38,10 (1.50)	42,39 (1.67)	54,0 (2.12)	62,0 (2.44)	9,52 (.375)
16	SAE "D" (J744-44-1)	44,45 (1.75)	49,46 (1.95)	67,0 (2.64)	75,0 (2.95)	11,11 (.438)
N	ISO 3019/2-E32N	32,00 (1.26)	35,00 (1.38)	58,0 (2.28)	68,1 (2.68)	10,00 (.393)

\* See torque limits on previous page.

## Spline Shafts\*

Shaft code	Shaft designation	Number of teeth	C	D
2	SAE "C" (J744-32-4)	14	48,0 (1.89)	56,0 (2.20)
3	SAE "CC" (J744-38-4)	17	54,0 (2.13)	62,0 (2.44)
12	SAE "D" (J744-44-4)	13	67,0 (2.64)	75,0 (2.95)

\* See torque limits on previous page.

# Installation Dimensions

## Basic Pump with Pressure Compensator and Load Sense Controls

Dimensions shown in mm (in.)

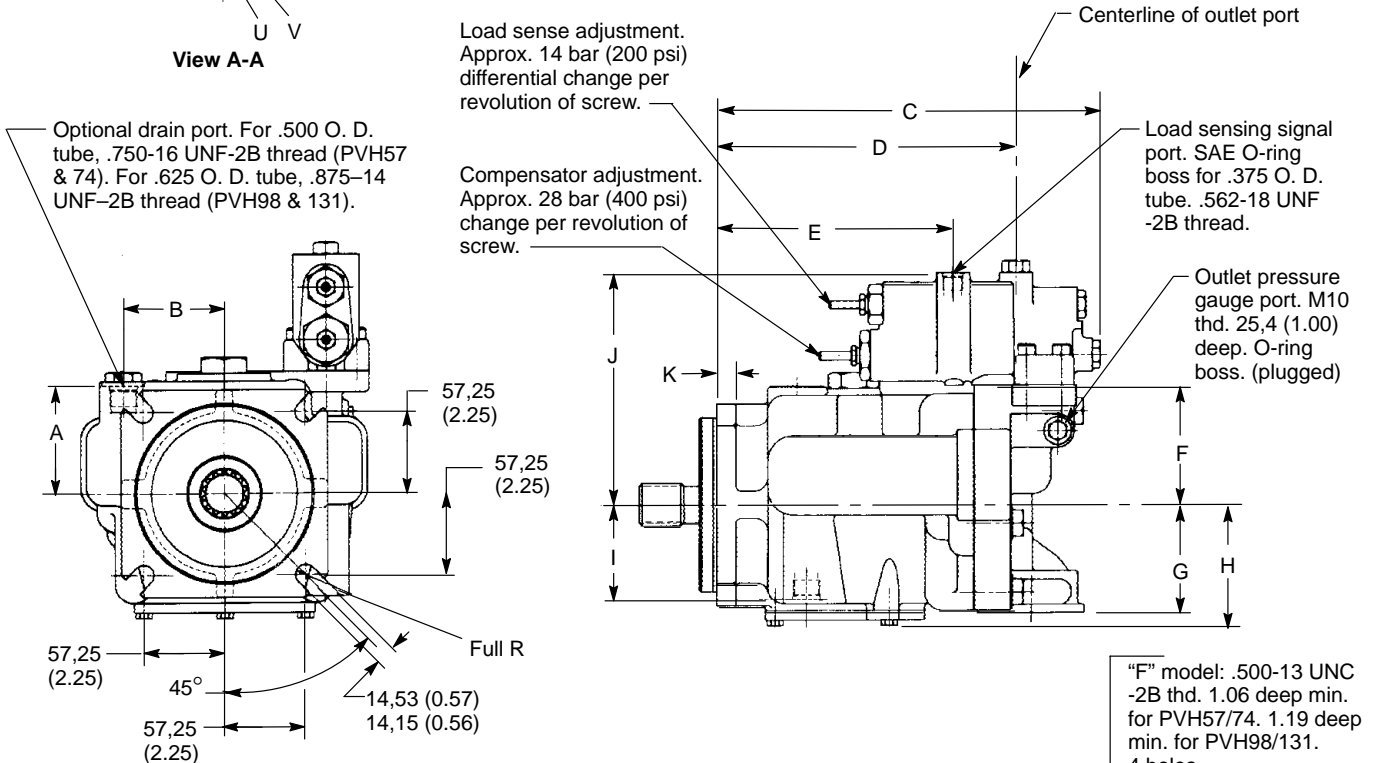
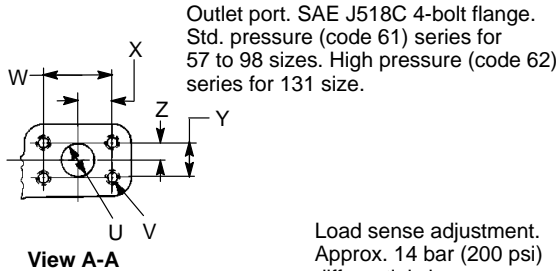
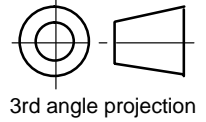

Drain port. SAE O-ring boss.  
.500 O. D. tube, .750-16 UNF-2B thread (PVH57 & 74).  
.626 O. D. tube, .875-14 UNF-2B thread (PVH98 & 131).

"F" model: .500-13 UNC -2B thd. 1.06 deep min. for PVH57/74. 1.19 deep min. for PVH98/131. 4 holes.

"M" model: M12 thd. 29 deep min. for PVH57/74. 31 deep min. for PVH98/131. 4 holes.

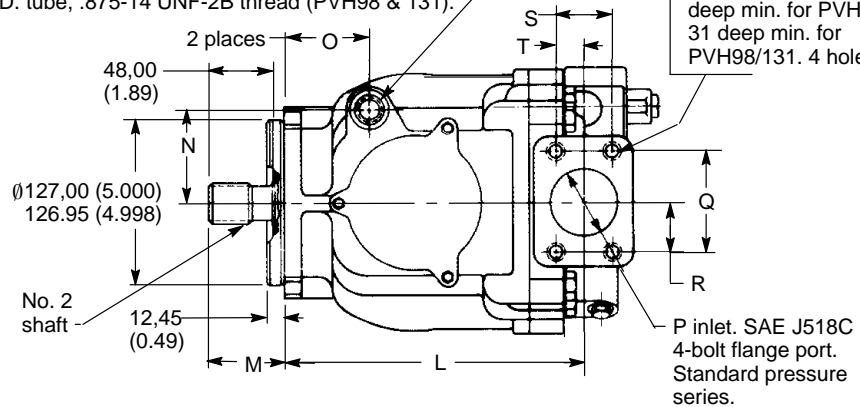

For shaft options and dimensions, see pages 14 and 15. Standard SAE pump mounting flange shown; see page 24 for optional SAE 2-bolt/4-bolt and ISO flanges. See page 25 for shaft-up mounting option.



# Installation Dimensions

## Basic Pump with Pressure Compensator and Load Sense Controls

	A	B	C	D	E	F	G	H	I
PVH57	76,0 (2.99)	71,0 (2.79)	293,0 (11.54)	216,5 (8.52)	171,3 (6.74)	86,0 (3.39)	79,0 (3.11)	88,0 (3.46)	69,0 (2.71)
PVH74	88,0 (3.46)	70,0 (2.75)	306,6 (12.07)	241,2 (9.50)	194,3 (7.65)	92,0 (3.62)	94,0 (3.70)	95,0 (3.74)	81,0 (3.19)
PVH98	93,1 (3.67)	85,0 (3.35)	323,5 (12.74)	251,3 (9.89)	206,1 (8.11)	94,5 (3.72)	87,5 (3.44)	97,1 (3.82)	80,1 (3.15)
PVH131	109,4 (4.31)	88,8 (3.50)	377,0 (14.84)	280,4 (11.04)	230,4 (9.07)	120,0 (4.72)	109,0 (4.29)	107,4 (4.23)	84,8 (3.34)

	J	K	L	M	N	O	P	Q	R
PVH57	168,0 (6.6)	14,0 (0.55)	227,4 (8.95)	56,1 (2.21)	71,0 (2.80)	64,8 (2.55)	50,8 (2.0)	77,77 (3.06)	38,88 (1.53)
PVH74	174,0 (6.85)	15,0 (0.59)	250,1 (9.85)	56,0 (2.20)	70,0 (2.75)	68,0 (2.68)	50,8 (2.0)	77,77 (3.06)	38,88 (1.53)
PVH98	176,5 (6.95)	16,0 (0.63)	269,3 (10.60)	55,5 (2.18)	85,0 (3.35)	74,2 (2.92)	63,5 (2.5)	88,9 (3.50)	44,45 (1.75)
PVH131	202,0 (7.95)	15,0 (0.59)	298,6 (11.75)	62,0 (2.44)	88,8 (3.50)	70,6 (2.78)	63,5 (2.5)	88,9 (3.50)	44,45 (1.75)

	S	T	U	V	W	X	Y	Z
PVH57	42,88 (1.69)	21,44 (0.84)	25,4 (1.0)	M10x1,5 (.375-16)	52,37 (2.06)	26,18 (1.03)	26,19 (1.03)	13,10 (0.52)
PVH74	42,88 (1.69)	21,44 (0.84)	25,4 (1.0)	M10x1,5 (.375-16)	52,37 (2.06)	26,18 (1.03)	26,19 (1.03)	13,10 (0.52)
PVH98	50,8 (2.0)	25,4 (1.0)	25,4 (1.0)	M10x15 (.375-16)	52,37 (2.06)	26,19 (1.03)	26,19 (1.03)	13,10 (0.52)
PVH131	50,8 (2.0)	25,4 (1.0)	31,75 (1.25)	M14x2,0 (.500-13)	66,68 (2.63)	33,34 (1.31)	31,75 (1.25)	15,88 (0.63)

# Installation Dimensions

## Basic Pump. Rear View with Various Controls.

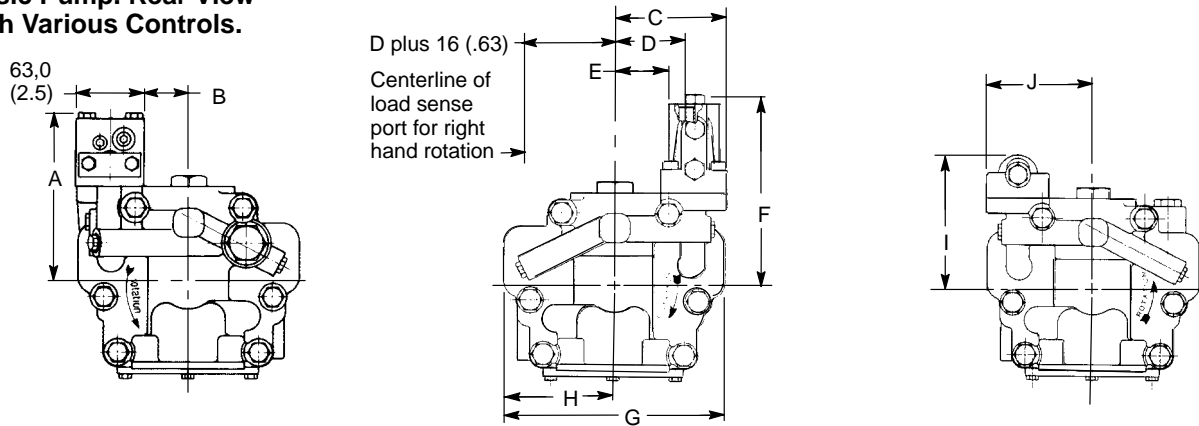

Right hand rotation, pressure compensated and torque limit model

Left hand rotation, pressure compensated and load sensing model

Right hand rotation, pressure compensated model

	A	B	C	D*	E	F	G	H	I	J
PVH57	176,45 (6.95)	41,0 (1.61)	102,7 (4.04)	64,5 (2.54)	49,0 (1.93)	176,6 (6.95)	203,0 (7.99)	101,5 (4.00)	127,0 (5.00)	102,7 (4.04)
PVH74	182,45 (7.18)	47,5 (1.87)	109,2 (4.30)	71,0 (2.79)	55,5 (2.19)	182,6 (7.18)	224,0 (8.82)	112,0 (4.41)	133,0 (5.23)	109,2 (4.30)
PVH98	195,45 (7.69)	41,0 (1.61)	102,7 (4.04)	65,5 (2.54)	49,0 (1.93)	185,1 (7.280)	233,0 (9.17)	116,5 (4.59)	135,5 (5.33)	102,7 (4.04)
PVH131	210,50 (8.29)	63,6 (2.50)	125,2 (4.92)	87,0 (3.42)	71,5 (2.81)	210,6 (8.29)	254,2 (10.00)	127,1 (5.00)	161,0 (6.37)	125,2 (4.92)

\*Add 16,0 (.63) to dimension D for right hand rotation model.

## Pump with Pressure Compensation, Load Sense and Torque Limit Controls

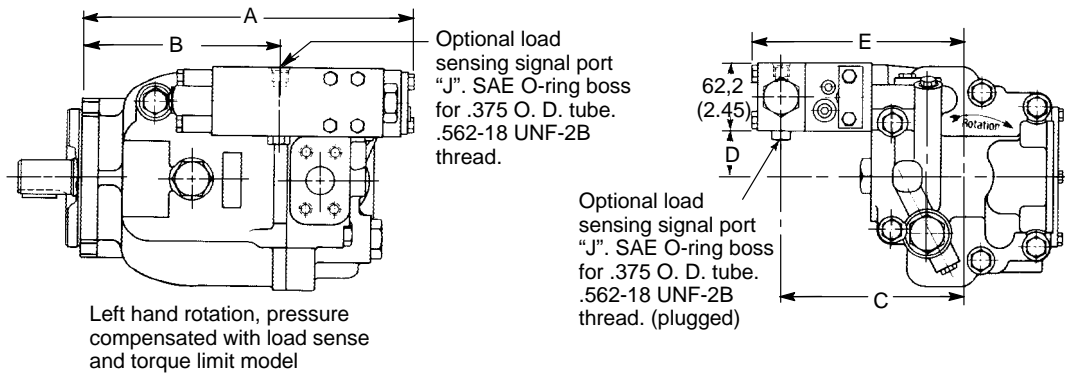

Left hand rotation, pressure compensated with load sense and torque limit model

Optional load sensing signal port "J". SAE O-ring boss for .375 O. D. tube. .562-18 UNF-2B thread. (plugged)

	A	B	C	D	E
PVH57	300,2 (11.82)	177,4 (6.98)	168,1 (6.62)	41,4 (1.63)	195,4 (7.69)
PVH74	322,9 (12.71)	200,1 (7.88)	174,1 (6.85)	47,9 (1.86)	201,4 (7.93)
PVH98	335,1 (13.19)	212,3 (8.36)	187,1 (7.37)	41,4 (1.63)	214,4 (8.44)
PVH131	359,5 (14.15)	236,6 (9.31)	202,2 (7.96)	63,8 (2.51)	229,5 (9.04)

# Installation Dimensions

## Pump with IC Compensator (Remotely Controllable Pressure Compensator, and Optional Load Sensing)

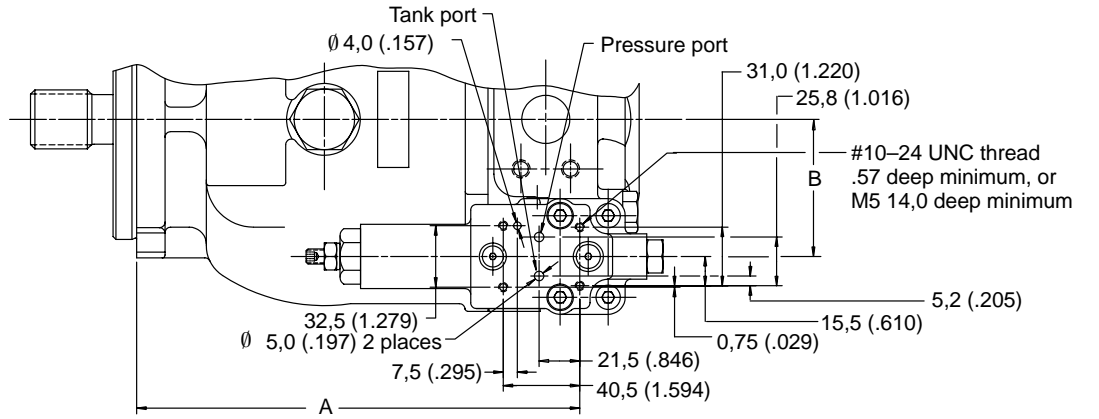

Control surface, ISO4401 size 03. Available with metric or UNC mounting holes to order

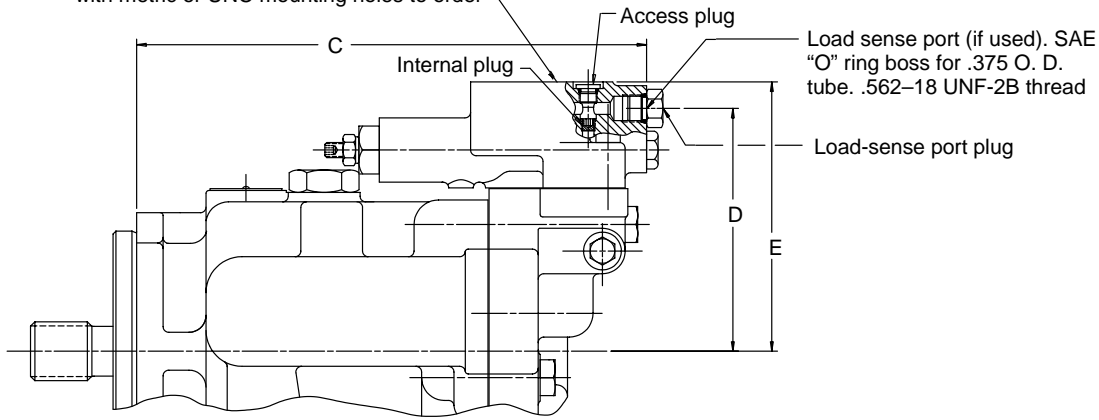

### Pressure compensator:

Remove access plug, using 1/8 inch hex wrench. Remove internal plug, using 5/32 inch hex wrench. Replace access plug and torque to 12,1-12,4 Nm (107-110 lb. in.). Attach relief valve hardware (not supplied) to control surface. See page 11 for more details.

### Pressure compensator with load sensing:

Remove load-sense port plug. (Internal plug must remain in place.) Attach line to load-sense port. Pressure decay rate of this line must not exceed 11 kbar/second (160 kpsi/second). Attach relief valve hardware (not supplied) to control surface. See page 11 for more details.

	A	B	C	D	E
PVH57	234,5 (9.23)	72,5 (2.85)	269,9 (10.62)	128,0 (5.04)	142,0 (5.59)
PVH74	257,2 (10.12)	79,0 (3.11)	292,6 (11.52)	134,0 (5.27)	148,0 (5.83)
PVH98	269,3 (10.60)	72,5 (2.85)	304,7 (12.00)	136,5 (5.37)	150,5 (5.92)
PVH131	293,6 (11.56)	95,0 (3.74)	329,0 (12.95)	162,0 (6.38)	176,0 (6.93)

# Installation Dimensions

## Pump with Adjustable Maximum Volume Stop

This option allows maximum pump delivery to be externally adjusted from 25 to 100 percent. To assist initial priming, adjust stop to allow at least 40 percent of maximum delivery. Adjust by loosening locknut and turning adjusting rod clockwise to decrease maximum delivery, or counterclockwise to increase maximum delivery. When desired setting is obtained, torque locknut to 25-50 Nm (18-36 lb. ft.).

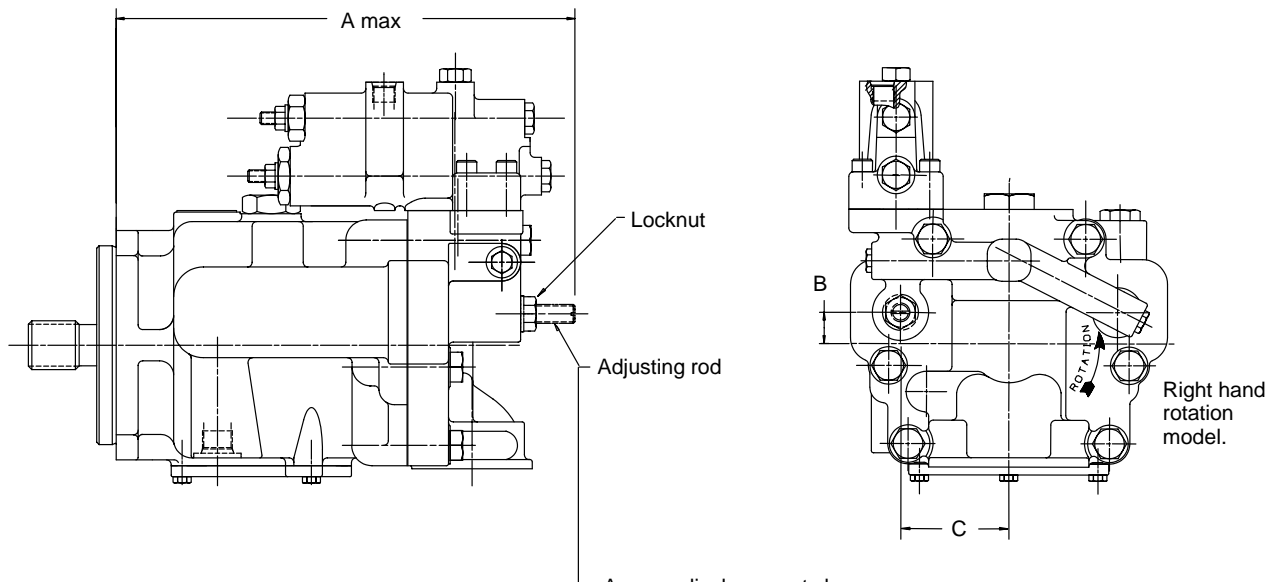

Approx. displacement change per revolution of rod:  
 PVH57 – 4,25 cm<sup>3</sup> (0.259 in<sup>3</sup>)  
 PVH74 – 5,00 cm<sup>3</sup> (0.305 in<sup>3</sup>)  
 PVH98 – 6,25 cm<sup>3</sup> (0.381 in<sup>3</sup>)  
 PVH131 – 8,50 cm<sup>3</sup> (0.519 in<sup>3</sup>)

	<b>A</b>	<b>B</b>	<b>C</b>
PVH57	293,0 (11.53)	20,0 (.79)	69.5 (2.74)
PVH74	306,6 (12.07)	22,0 (.87)	76,0 (2.99)
PVH98	323,5 (12.74)	27,5 (1.08)	81,0 (3.19)
PVH131	377,0 (14.84)	37,5 (1.48)	88,8 (3.50)

# Installation Dimensions

## Thru-drive Pumps with SAE "A" Rear Pad

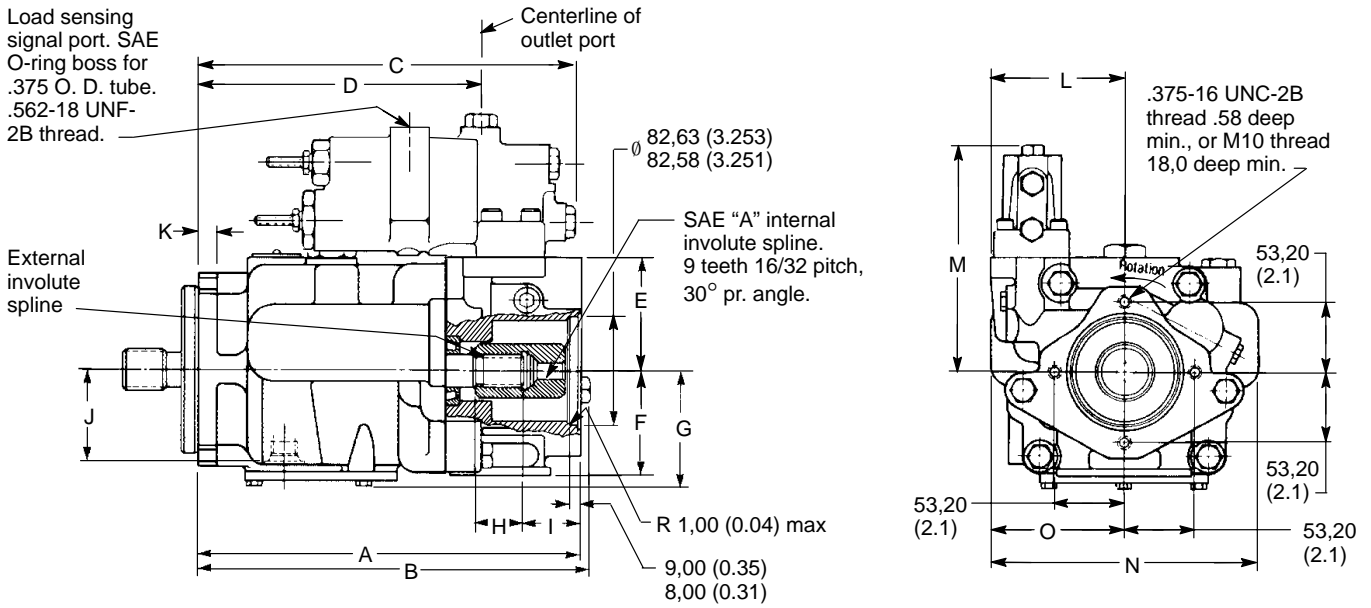

For shaft options and dimensions, see pages 14 and 15. See page 24 for optional cover for rear pad.

Note: The O-ring for sealing the rear mounting pad is furnished with the pump. The rear drive coupling shown must be ordered separately; see page 23

Right hand rotation, pressure compensated and load sensing model.

	A	B	C	D	E	F	G	H
PVH57	287,9 (11.3)	295,4 (11.6)	275.8 (10.86)	216,4 (8.52)	86,0 (3.38)	79,0 (3.11)	88,0 (3.46)	36,4 (1.43)
PVH74	310.6 (12.23)	318,1 (12.52)	300,5 (11.83)	241,2 (9.50)	92,0 (3.62)	94,0 (3.70)	95,0 (3.74)	38,5 (1.51)
PVH98	322,8 (12.71)	N/A	312,7 (12.31)	251,3 (9.89)	94,5 (3.72)	87,5 (3.44)	97,1 (3.82)	33,0 (1.30)
PVH131	347,1 (13.660)	N/A	337,0 (13.27)	280,4 (11.04)	120,0 (4.72)	109,0 (4.29)	107,4 (4.23)	35,3 (1.39)

	I	J	K	L	M	N	O
PVH57	43,6 (1.72)	69,0 (2.71)	14,0 (0.55)	102,7 (4.04)	176,6 (6.95)	203,0 (7.99)	101,5 (4.00)
PVH74	43,8 (1.72)	81,0 (3.19)	15,0 (0.59)	109,2 (4.30)	182,6 (7.18)	224,0 (8.82)	112,0 (4.41)
PVH98	44,6 (1.75)	80,1 (3.15)	16,0 (6.30)	102,7 (4.04)	185,1 (7.28)	233,0 (9.17)	116,5 (4.59)
PVH131	44,7 (1.76)	84,8 (3.34)	15,0 (0.59)	125,2 (4.93)	210,6 (8.29)	254,2 (10.0)	127,1 (5.00)

# Installation Dimensions

## Thru-drive Pumps with SAE "B" Rear Pad Adapter

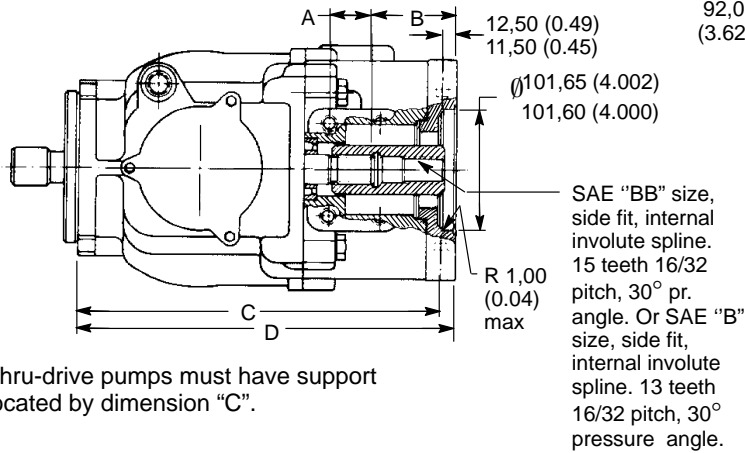

Thru-drive pumps must have support located by dimension "C".

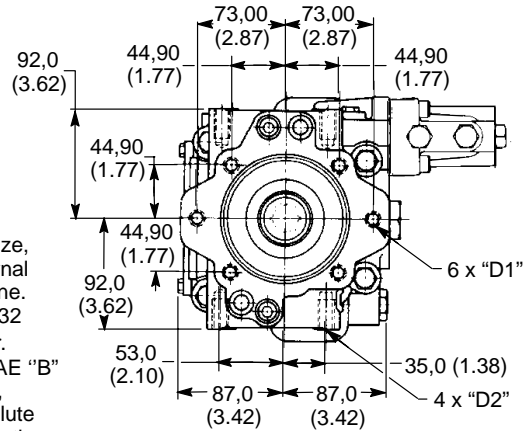

SAE "B" rear mounting. Mounting pad is machined to accept AS568-155 O-ring. Mounting pad is connected to pump case and must be sealed.

## Thru-drive Pumps with SAE "C" Rear Pad Adapter

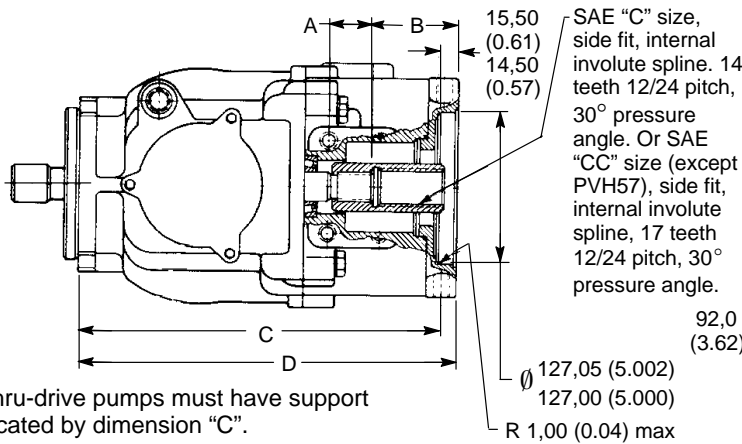

Thru-drive pumps must have support located by dimension "C".

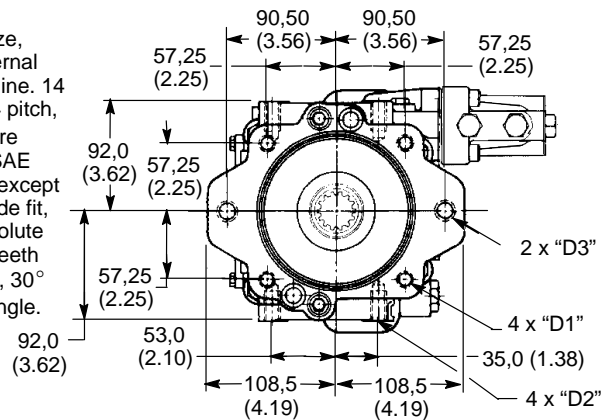

SAE "C" rear mounting. Mounting pad is machined to accept AS568-159 O-ring. Mounting pad is connected to pump case and must be sealed.

Pump Model	A	B	C	D
PVH57	36,4 (1.43)	68,8 (2.71)	300,4 (11.82)	312,9 (12.32)
PVH74	33,5 (1.32)	68,3 (2.69)	323,1 (12.72)	335,6 (13.21)
PVH98	33,0 (1.30)	69,8 (2.75)	335,3 (13.20)	347,7 (13.69)
PVH131	35,3 (1.39)	69,7 (2.74)	359,6 (14.16)	372,1 (14.65)

	D1	D2	D3
Metric	M14x2,00 25 deep	M12x1,75 25 deep	M16x2,00 25 deep
Inch	0,500-13 UNC-2B 1.0 deep	0,500-13 UNC-2B 1.0 deep	0,625-11 UNC-2B 1.0 deep

Note: The O-ring for sealing the rear mounting pad is furnished with the pump. The rear drive couplings shown must be ordered separately; see following page.

## Thru-drive Flange Kit and Shaft Coupling

Front pump model series	SAE (J744) mounting flange for rear pump	Mounting flange adapter kit number*		Coupling part number**
		Metric threads	Inch threads	
PVH57	A (J744-82-2)	None required	None required	526682
	B (J744-101-2/4)	876394	876390	526694
	BB (J744-101-2/4)	876394	876390	526695
	C (J744-127-2/4)	876392	876389	526696
PVH74	A (J744-82-2)	None required	None required	864460
	B (J744-101-2/4)	876394	876390	864457
	BB (J744-101-2/4)	876394	876390	864459
	C (J744-127-2/4)	876392	876389	864458
	CC (J744-127-2/4)	876392	876389	864461
PVH98	A (J744-82-2)	None required	None required	877039
PVH131	B (J744-101-2/4)	876394	876390	877040
	BB (J744-101-2/4)	876394	876390	877044
	C (J744-127-2/4)	876392	876389	877045
	CC (J744-127-2/4)	876392	876389	877046

\*The basic PVH thru-drive pump has an SAE "A" pad on the rear. An SAE "B" or "C" pad rear mounting requires flange adapters. Required adapters can be provided if specified in the pump model code. The best combination of price, availability and flexibility is achieved by ordering a PVH SAE "A" thru-drive model and the applicable PVH mounting flange adapter separately. For example, a PVH74C-RCF-3S-10-C25-31 may also be ordered as a PVH74C-RAF-3S-10-C25-31 and a 876389 flange adapter.

\*\* Thru-drive shaft couplings must be ordered separately to drive the second pump.

## Typical Rear Pumps for Thru-drive Assemblies

Mountng	Piston pump series	Shaft code	Vane pump series	Shaft code
SAE A	PVQ10/13	3	V10	11
			V20	62
SAE B	PVQ20/32	3	20V	151
	PVQ40/45	3	25V	11
	PVE19/21	9	V2020	11
SAE BB	PVE19/21	2		
	TA19	2		
SAE C	PVH57	2	35V	11
	PVH74	2	352*V	11
	PVH98	2		
SAE CC	PVH131	3		

NOTE: The above Vickers pumps are examples of rear pumps for the thru-drive pumps dimensioned on pages 21 and 22. The thru-drive torque limits identified in the chart on page 14 must not be exceeded when applying these multiple pump systems.

**ISO 3019/2-125B4HW Mounting Flange for PVH57 and PVH74 Pumps**

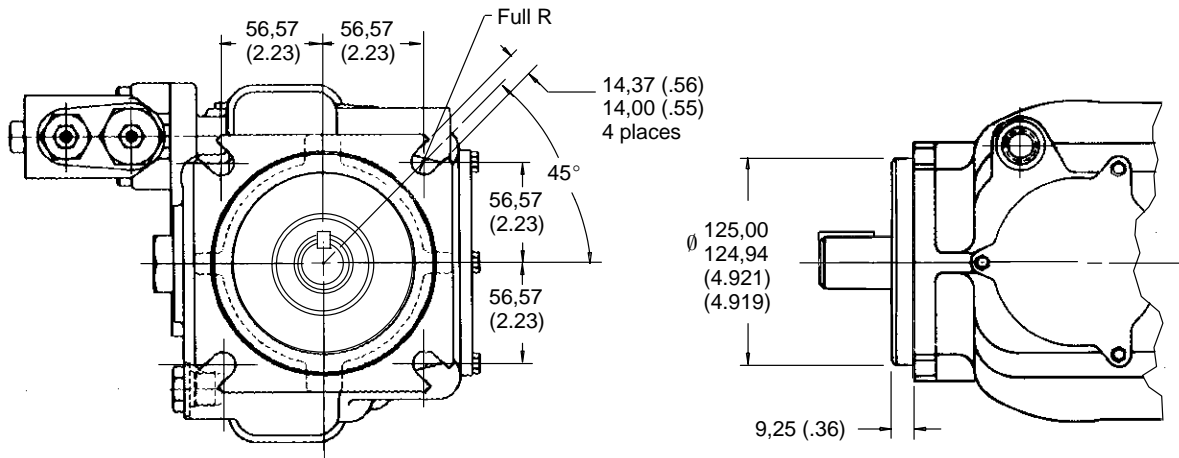

**SAE 2-bolt/4-bolt Mounting ("027" Option) for PVH57, PVH74 and PVH98 Pumps**

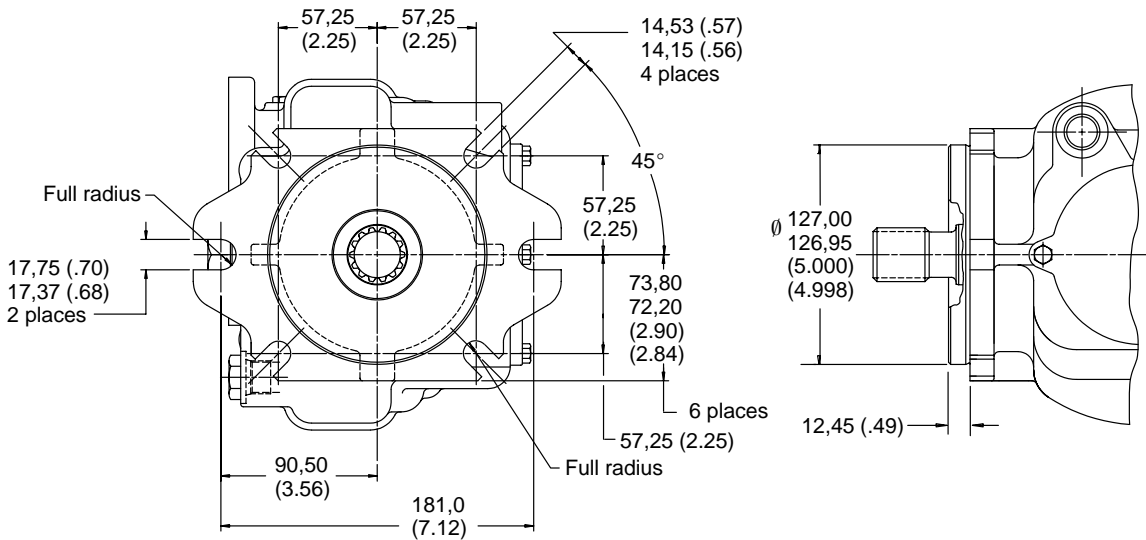

**Cover ("031" Option) for Thru-drive SAE "A" Rear Mounting Flange**

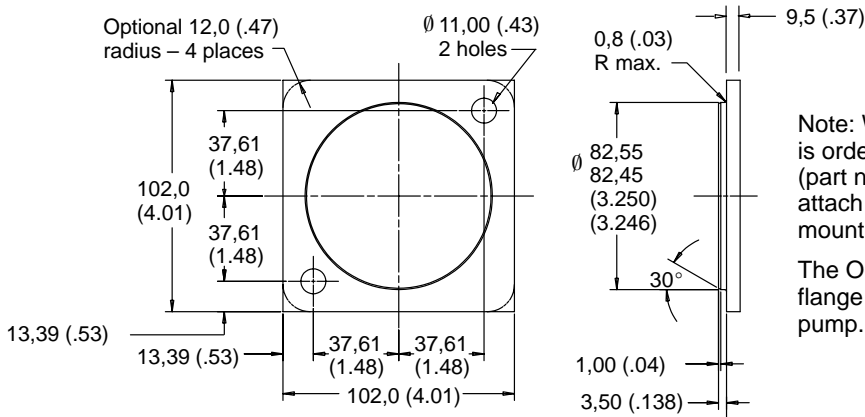

Note: When cover (part number 939790) is ordered as a separate part, two screws (part number 170177) are required to attach the cover to the pump's rear mounting flange.

The O-ring for sealing the rear mounting flange is furnished with each thru-drive pump.



**Pumps for Shaft-up Operation (Vertical Mount, "057" Option)**

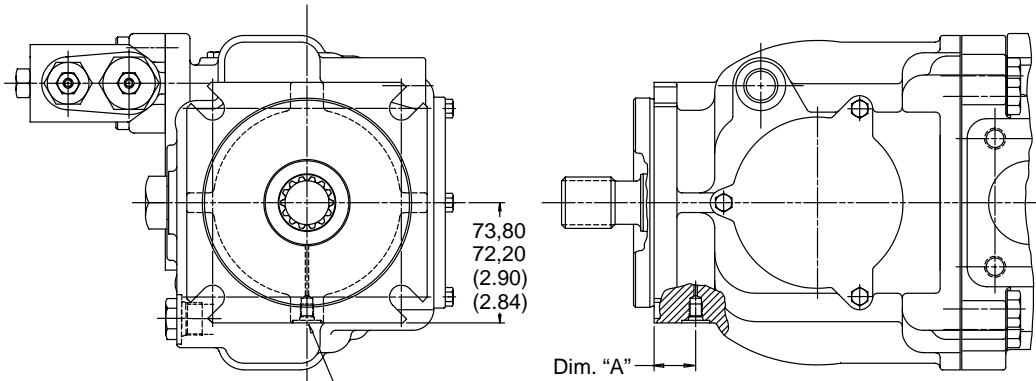

Model	Dim. "A"
PVH57	25,68/24,94 (1.01/0.98)
PVH74	26,64/25,90 (1.05/1.02)
PVH98	25,82/25,08 (1.02/0.99)
PVH131	25,12/24,38 (.99/0.96)

Vertical mount port.  
For .125 O. D. tube.  
.3125-24 UNF-2B thread.  
1,59 (.0625) maximum  
spotface depth

Attach line from this port to primary case drain line. Join these lines at a distance above the face of the mounting flange that equals, or is less than, dimension "A". Fill case with fluid up to this port prior to start-up.

**Model FB-C4-10 Foot Mounting Kit for All PVH Pumps**

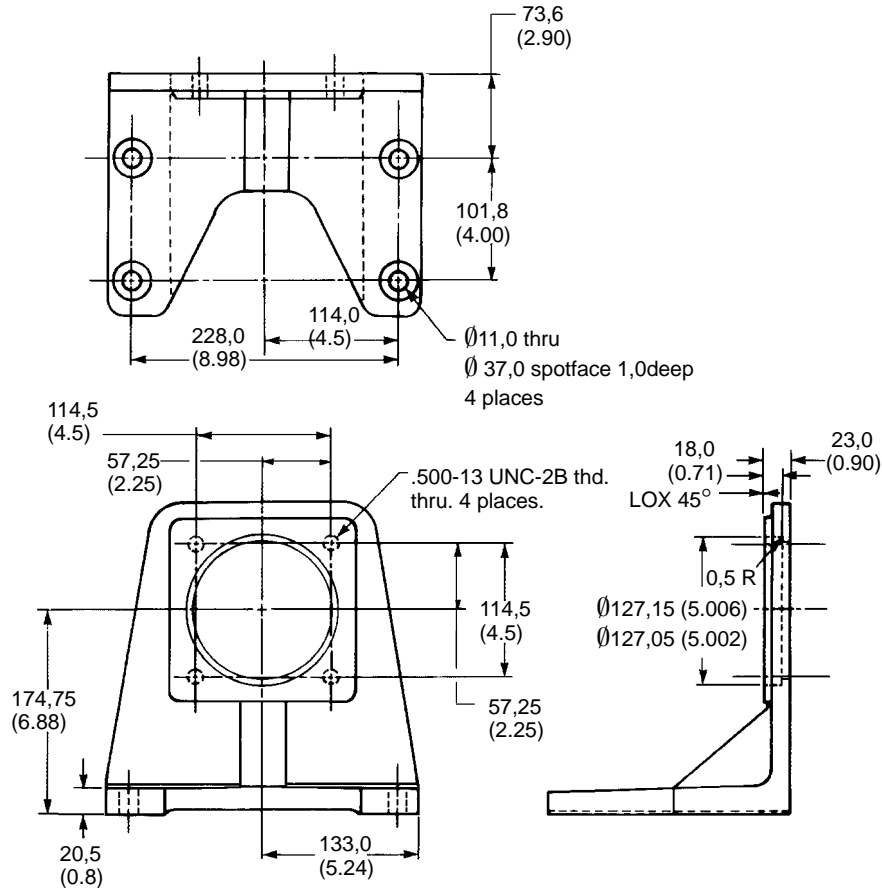

Each kit (part no. 02-143419) includes bracket shown and four screws for mounting to the pump. Kits are not included with pumps and must be ordered separately by model number.

# Application Data

## Hydraulic fluids and temperature ranges

Use anti-wear hydraulic oil, or automotive type crankcase oil (designations SC, SD, SE or SF) per SAE J183 FEB80.

Select a viscosity grade that will allow optimum viscosity, between 40 cSt (180 SUS) and 16cSt (80 SUS), to be achieved.

Cold start capability at 5000 cSt.  
Max. intermittent temp. 104° C (220° F).

For further information, see 694.

## Fluid cleanliness

Proper fluid condition is essential for long and satisfactory life of hydraulic components and systems. Hydraulic fluid must have the correct balance of cleanliness, materials and additives for protection against wear of components, elevated viscosity and inclusion of air.

Essential information on the correct methods for treating hydraulic fluid is included in Vickers publication 561; "Vickers Guide to Systemic Contamination Control," available from your local Vickers distributor or by contacting Vickers, Incorporated. Recommendations on filtration and the selection of products to control fluid condition are included in 561.

Recommended cleanliness levels, using petroleum oil under common conditions, are based on the highest fluid pressure levels in the system and are coded in the chart below. Fluids other than petroleum, severe service cycles or temperature extremes are cause for adjustment of these cleanliness codes. See Vickers publication 561 for exact details.

Vickers products, as any components, will operate with apparent satisfaction in fluids with higher cleanliness codes than those described. Other manufacturers will often recommend levels above those specified. Experience has shown, however, that life of any hydraulic components is shortened in fluids with higher cleanliness codes than those listed below. These codes have been proven to provide a long trouble-free service life for the products shown, regardless of the manufacturer.

## Drive data

Mounting attitude should be horizontal. See preceding page for vertical mount option. Consult your local Vickers representative if a different arrangement is required.

Direction of shaft rotation, viewed at the prime mover end, must be as indicated in the model designation on the pump. See "5" in Model Codes, page 4.

Drive arrangement should be by direct drive through a flexible coupling. Check pump installation drawing for concentricity and squareness tolerances.

Torque capability of shafts in basic (non-thru-drive) pumps is well in excess of that needed for operation at rated pressure and maximum displacement. Limitations for multiple pumps formed by PVH thru-drives as front-end sections are specified in the chart on page 14.

## Moment of Inertia (Single Pump Rotating Group)

Model	Nm.sec <sup>2</sup>	(lb.in.sec <sup>2</sup> )
PVH57	0,0054	(0.0475)
PVH74	0,0078	(0.0692)
PVH98	0,0134	(0.1189)
PVH131	0,0210	(0.1862)

## Cleanliness codes for petroleum oil usage

Product	System Pressure Level		
	< 2000 psi	2000-3000 psi	3000+ psi
Vane pumps, fixed	20/18/15	19/17/14	18/16/13
Vane pumps, variable	18/16/14	17/15/13	
Piston pumps, fixed	19/17/15	18/16/14	17/15/13
Piston pumps, variable	18/16/14	17/15/13	16/14/12
Directional valves	20/18/15	20/18/15	19/17/14
Proportional valves	17/15/12	17/15/12	15/13/11
Servo valves	16/14/11	16/14/11	15/13/10
Pressure/Flow controls	19/17/14	19/17/14	19/17/14
Cylinders	20/18/15	20/18/15	20/18/15
Vane motors	20/18/15	19/17/14	18/16/13
Axial piston motors	19/17/14	18/16/13	17/15/12
Radial piston motors	20/18/14	19/17/13	18/16/13

# Weights, Ordering, Installation/Start-up

## Weights in kg (lb)\*

Pump Size	Basic Pump	Thru-drive Pump SAE "A"
PVH57	30-36 (66-79)	31-37 (68-82)
PVH74	39-45 (86-99)	42-48 (93-106)
PVH98	43-49 (95-108)	44-50 (97-110)
PVH131	60-66 (132-145)	62-68 (137-150)

\*Approximate dry weights. Weight for a given model depends upon the type of pump control selected.

## Ordering Procedure

Order PVH pumps by the full model designation. Pump displacement, mounting flange type, direction of rotation, pump configuration, shaft end type, shaft seals, pressure adjustment range, specific control functions, and torque limiter settings are all specified in the full model code.

Various Vickers relief valves are suitable for use with the "IC" compensator and must be ordered separately.

Examples include:

- DGMC2-3-AT-BT (plus DG4V-3-8C directional valve) for remotely and electrically controlled dual-pressure compensation, and standby no-flow pump operation in the load sensing mode.
- DGMC-3-PT-FW-30 crossline relief module (with DG4V3-8C directional valve) for electrical selection of dual pressure compensation.
- ECGF-02-9-21 proportional relief valve, with feedback, for remote control of pressure compensation.
- ECG-02-9-30 proportional relief valve for remote control of pressure compensation.

- DGMC-3-AT-BT (plus DG4V-3-0A directional valve) for remotely and electrically selected dual-pressure compensation.
- C175-F-20 (plus blanking plate DGMA-3-B-11 and tapping plate DGMA-T2-20-S) for remote control of pressure compensation.
- CVGC-3-S12 for non-remote control of pressure compensation.
- DGMC-3-PT-FW-30 crossline relief module (with blanking plate DGMA-3-B-11) for non-remote control of pressure compensation.

Contact your Vickers representative for additional information on the application and ordering of relief valves.

## Installation and Start-up

The installation of PVH pumps must be in accord with the data on pages 14 and 23.

Before the pump is started, fill the case through the uppermost drain port with hydraulic fluid of the type to be used. The case drain line must be connected directly to the reservoir and terminate below the oil level. If the pump has the vertical-mount option, attach a secondary drain line as noted on page 25.

Maximum continuous pressure at the case drain port must not exceed 0,5 bar (7 psi). For multiple pump arrangements that include non-PVH sections, the requirements of the non-PVH units must be considered.