

Piston distributors, Group 390 0.2-1.5 ccm (for oil)

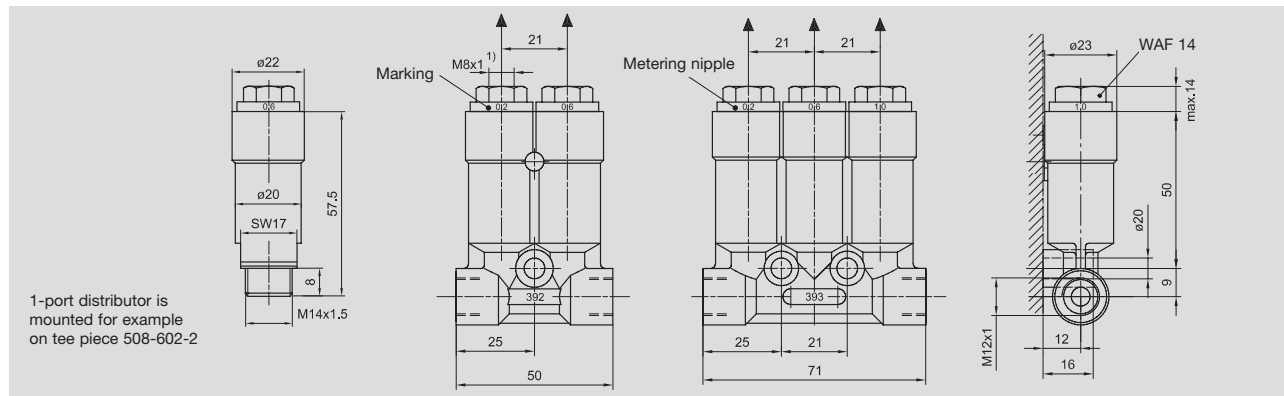

1-port distributor is mounted for example on tee piece 508-602-2



Piston distributors (available only with metering nipples installed)

Order No.	Number of lube points
391-0.0-000	1
392-0..-000	2
393-0..-000	3

To order: the order No. has 9 places

To complete the order No. supplement it with the **order key** in keeping with the desired metered quantities.

Order example: piston distributor, 3-port type, 393-0..-000
metered with (from left to right) 1.5 – 1.0 – 0.4 ccm

Order key: 9 8 6

Order No.: 393-098-600

Metering nipple with O-ring, exchangeable

Rated metered quantity [ccm]	Order key	Marking on the metering nipple	Order No.
0.2	5	0.2	391-020-K
0.4	6	0.4	391-040-K
0.6	7	0.6	391-060-K
1.0	8	1.0	391-100-K
1.5	9	1.5	391-150-K