

The Lube Sentry Valve provides automatic warning and shutdown of compressors, pumps and engines when oil is not flowing properly to primary dividers in series type lube systems.

PNEUMATIC LUBE SENTRY VALVE

Pneumatic shutdown can be achieved with the Pneumatic Lube Sentry which meets all hazardous condition area requirements.

ELECTRIC LUBE SENTRY VALVE

For electric shutdown of machinery, the Electric Lube Sentry is available.

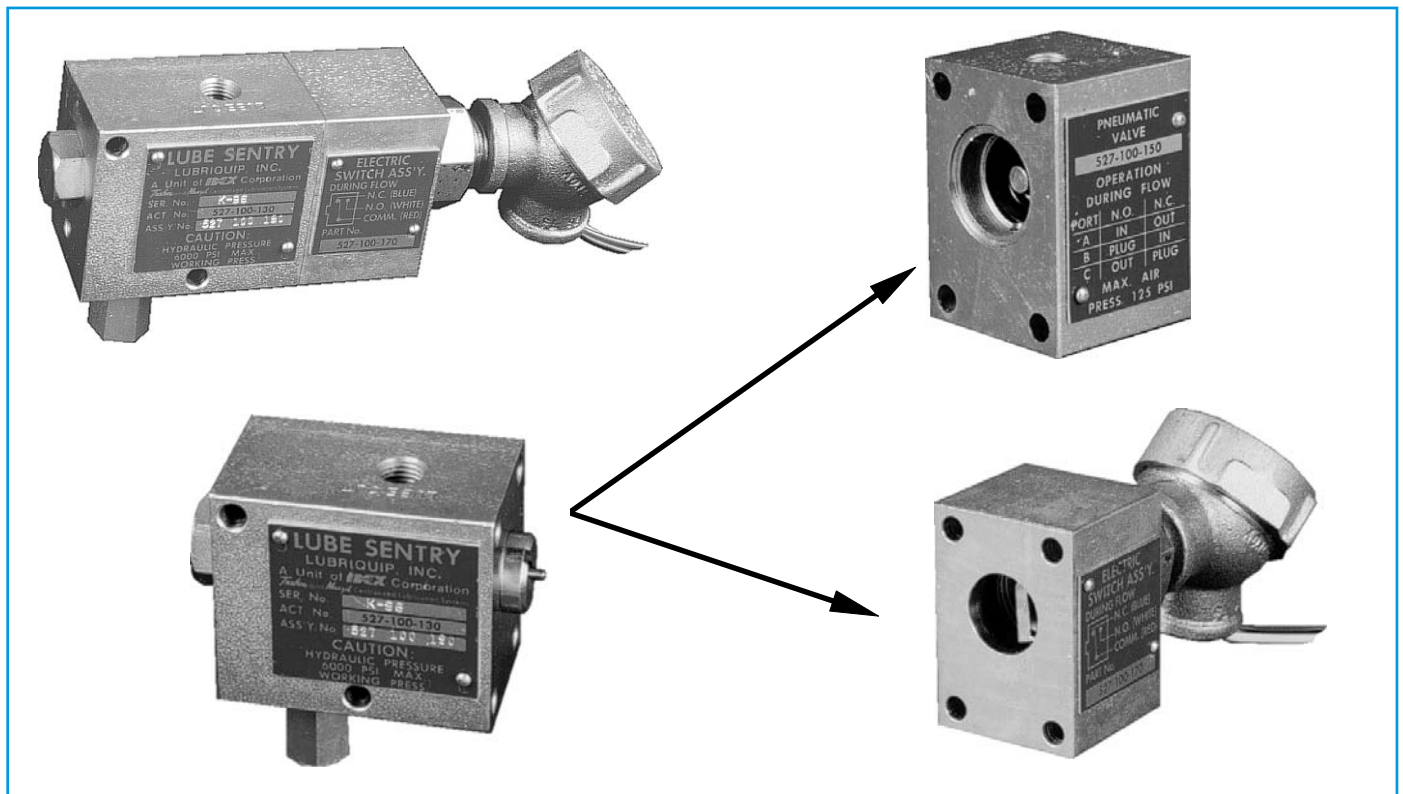

DESCRIPTION

The Lube Sentry is a simple, compact unit that installs in the main lube line between the lube pump and master divider, and downstream from any meters or filters (recommended) between the pump and the divider.

It consists of two separate units - an actuator and a 3-way pneumatic valve on the Pneumatic Lube Sentry, and an actuator and microswitch assembly on the Electric Lube Sentry - that are bolted together. It's designed for use in series type systems with flow rates ranging from 4 to 400 pints of oil per day at pressures up to 6,000 psi (414 bar).

The Pneumatic Lube Sentry can also be used to control pilot pressure to compatible air safety shutdown valves on gas compressor engines.

FEATURES/BENEFITS

The Pneumatic and Electric Lube Sentry also feature:

- Absence of check valves to avoid trapping contamination from included solids in the lubricant.
- Bolted-together components simplifying maintenance. The microswitch assembly on the pneumatic valve can be removed without disturbing existing lines or shutting down the equipment being lubricated.

OPERATION

Starting the engine initiates lubricant flow from the lube pump serving the MH distribution system (until flow has been established, the electric or pneumatic circuit to the Lube Sentry must be bypassed). Lubricant passing through the hydraulic section of the valve (See Figure 1 or 2) from port (1) to port (2) moves to piston (3) in the direction of the arrow. The actuator rod (4) is attached to piston (3) and simultaneously moves in the same direction allowing the directional spool (5) in the air valve of the Pneumatic Lube Sentry (See Figure 1) to permit air to flow between port "A" and port "C" or tripping the microswitch(s). (See Figure 2 Note 2 on the Electric Lube Sentry.) The Lube Sentry is now in a flow position.

When lubricant flow stops, spring (6) returns piston (3) in the opposite direction, closing the porting to the lube outlet (7). The lubricant ahead of piston (3) is forced back through the adjustable needle valve (8) at a controlled rate. As piston (3) returns to the right the attached actuator rod (4) moves, the Pneumatic Lube Sentry directional spool (5), permitting air to now flow between port "A" and port "B" (See Figure 1), or changing the position of the microswitch(s) (See Figure 2 Note 2) on the Electric Lube Sentry. The Lube Sentry is now in a no-flow condition. Figure 1 shows a typical no-flow position.

Adjusting needle valve (8) clockwise increases shutdown time. A counterclockwise adjustment decrease the shutdown time.

Figure 1
Pneumatic Lube Sentry Valve

Note 1: Pneumatic Valve Operation
(During Lubricant Flow)

Operation	Port "A"	Port "B"	Port "C"
Norm. Open	Air In	Plugged	Air Out
Norm. Closed	Air Out	Air In	Plugged

SHUTDOWN ADJUSTMENT:
CLOCKWISE-
INCREASE SHUTDOWN TIME
COUNTER CLOCKWISE-
DECREASE SHUTDOWN TIME

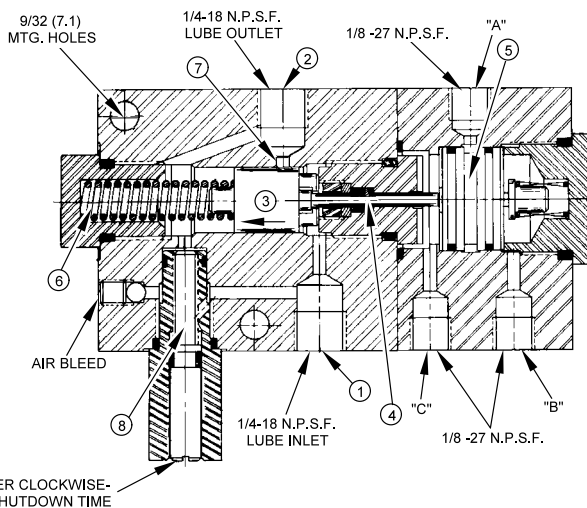

Figure 2
Electric Lube Sentry (Flow / No-Flow)

Note 2:

FLOW CONDITION-

For Closed Contact: Use Red and Blue Wires (Red Common)
For Open Contact: Use Red and White Wires (Red Common)

NO-FLOW CONDITION-

For Open Contact: Use Red and Blue Wires (Red Common)
For Closed Contact: Use Red and White Wires (Red Common)

CAUTION: If only two of the three wires are used, tape unused wire.

Flow - Green Light "ON"; Red Light "OFF"
No-Flow - Right Light "ON"; Green Light "OFF"

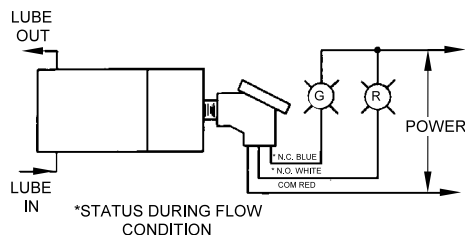
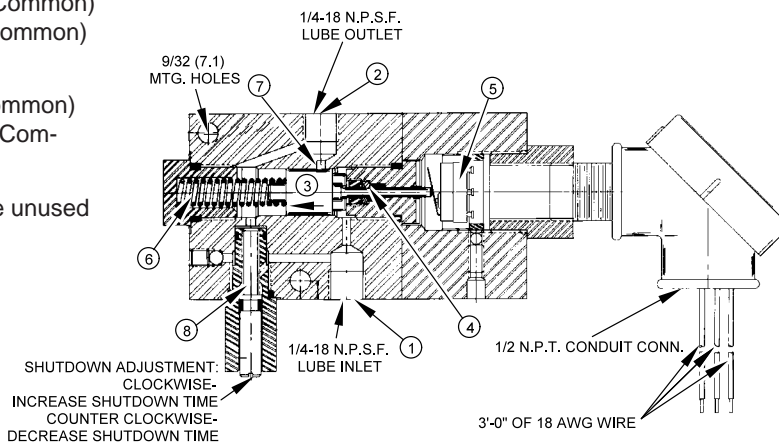

Typical Series Installation of Pneumatic Shutdown Circuit

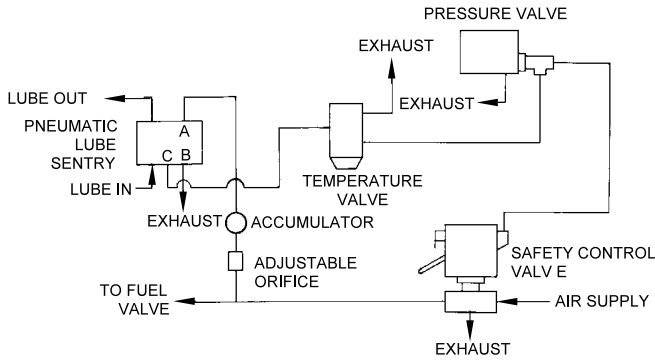

Typical Electric Lube Sentry Installation

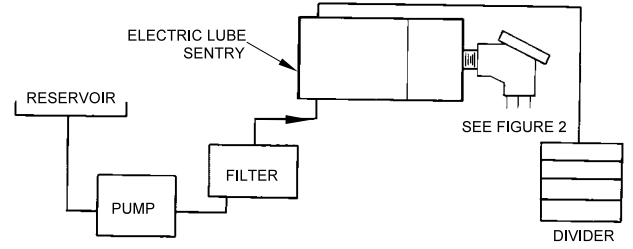

DIMENSIONS Inches (mm)

PNEUMATIC LUBE SENTRY VALVE

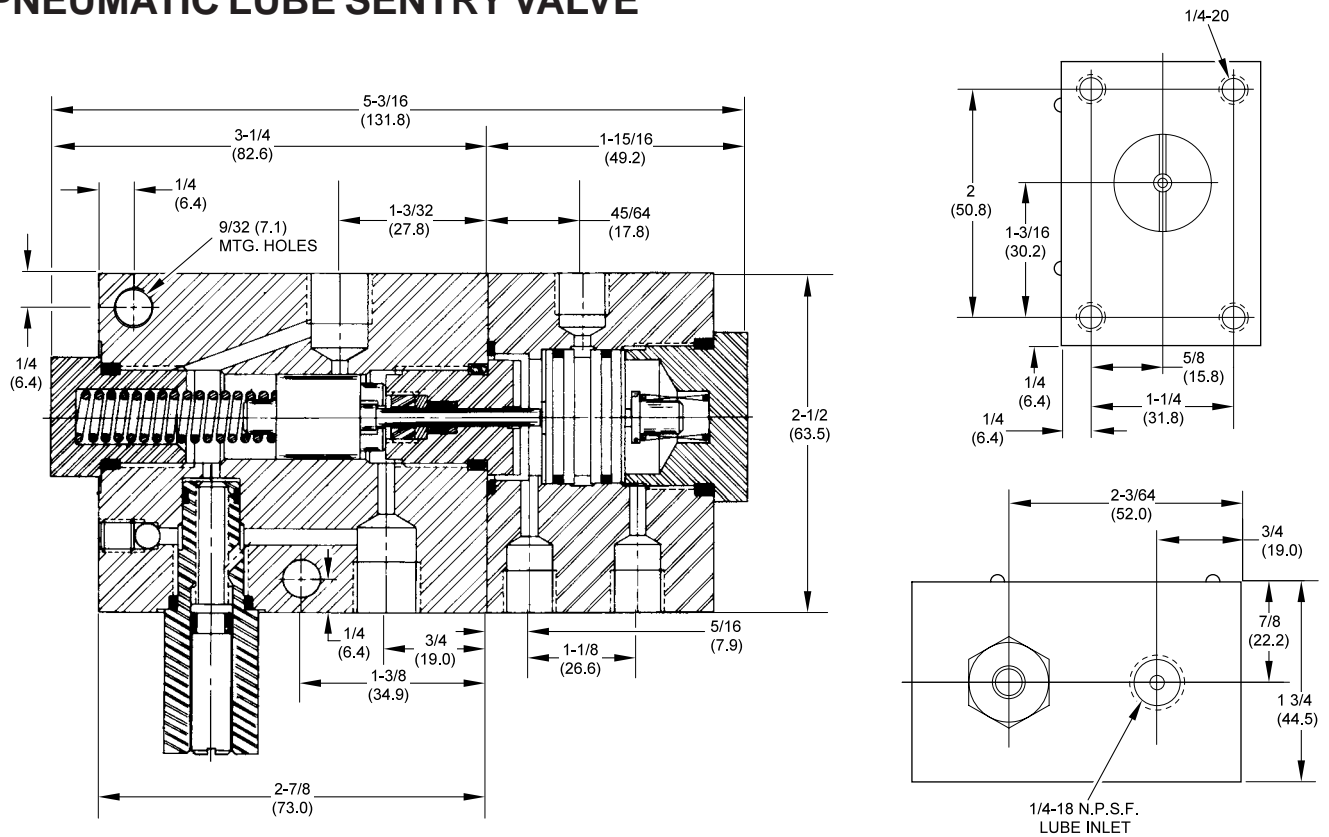

DIMENSIONS Inches (mm)

ELECTRIC LUBE SENTRY VALVE

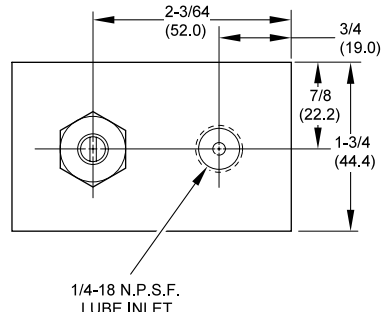
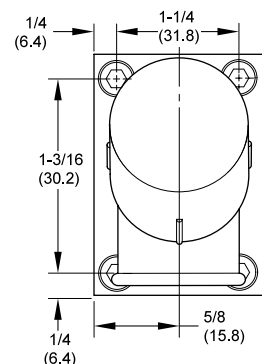
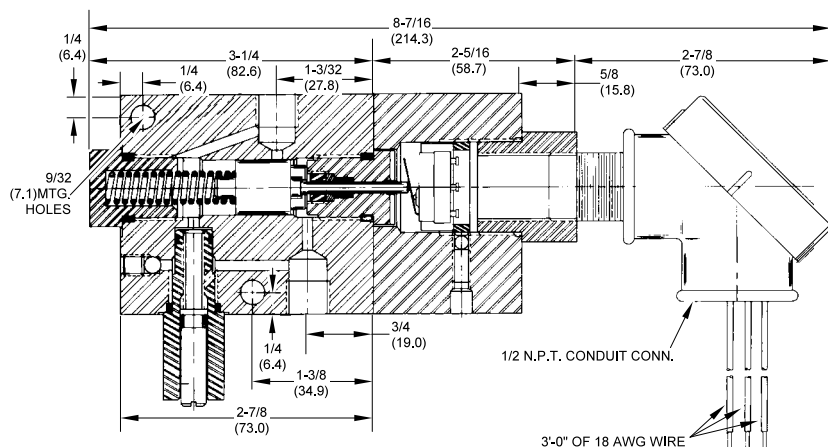

SPECIFICATIONS

Material	Steel
Max. Pressure	6,000 psi (414 bar)
** Flow rate (per day) Max.	400 pints (189.2 liters) Min. 4 pints (1.89 liters)
Pressure Drop	250 PSI (17 bar)
Seals	Viton*
** Lubricant	Oil (450 to 2,000 SUS)
Net Weight	5 lb. (2.265 kg)
Operating temperature	-20 to 180°F (-29 to 82°C)
Air Pressure (Max. Pneumatic Valve)	125 psi (9 bar)
Electrical Rating:1)	5 amps @ 125 / 250 VAC
2)	A, B, or C @ 28 VDC
A - Inductive	3 AMP
B - Resistive	5 AMP
C- Max. Inrush	15 AMP

ORDERING INFORMATION

ITEM	PARTNUMBER
Pneumatic Lube Sentry, complete	527-100-190
Pneumatic Valve	527-100-150
Actuator	527-100-130
Electric Lube Sentry, complete	527-100-180
Switch Assembly	527-100-170
Actuator	527-100-130

For more information on the Pneumatic or Electric Lube Sentry Valve consult Literature No. 45425 or your Trabon / Manzel Distributor.

Look to LUBRIQUIP, INC., for all of your Centralized Lubrication System needs.

Products include:

DIVIDER VALVES: for oil and grease...to 7500 PSI...1 to 20 points from a single valve assembly...up to 400 points from a Master/ Secondaries circuit...or systems that handle an entire plant.

PUMPS: fixed and variable displacement...manual and air, hydraulic, electric motor or mechanically driven.

TIMERS / AUTOMATIC CONTROLS: from simple on/off to complete flow and pressure monitoring, either timer-or machine-actuated.

ACCESSORY VALVES: balancing, check and flow.

INDICATORS: performance and broken line.

ACCESSORIES: fittings, brackets, clamps, filters and strainers.