

Piston distributors, Group 350 0.1-0.6 ccm (for oil)

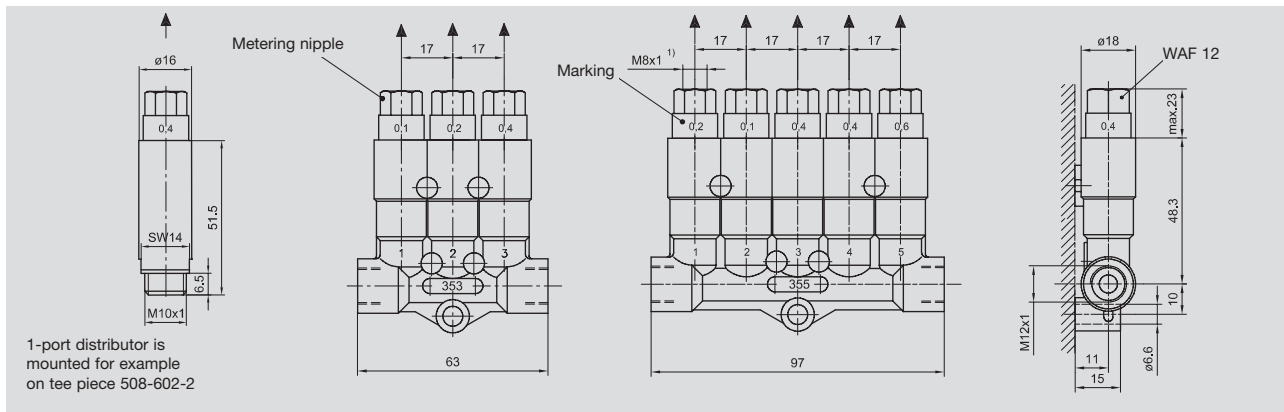

Piston distributors

(available only with metering nipples installed)

Order No.	Number of lube points
351-0.0-000	1
352-0..-000	2
353-0..-.00	3
355-0..-...	5

Metering nipple with O-ring, exchangeable

Rated metered quantity [ccm]	Order key	Marking on the metering nipple	Order No.
0.1	4	0.1	352-010-K
0.2	5	0.2	352-020-K
0.4	6	0.4	352-040-K
0.6	7	0.6	352-060-K

To order: the order No. has 9 places

To complete the order No. supplement it with the **order key** in keeping with the desired metered quantities.

Order example: piston distributor, 3-port type, 353-0..-.00

metered with (from left to right) 0.1 – 0.4 – 0.2 ccm

Order key: 4 6 5

Order No.: 353-046-500